

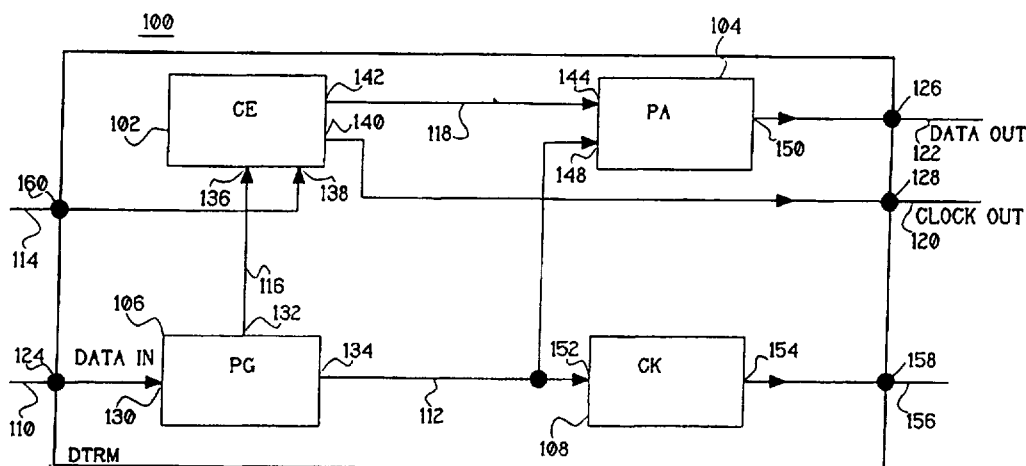

INTERNATIONAL APPLICATION PUBLISHED UNDER THE PATENT COOPERATION TREATY (PCT)

<p>(51) International Patent Classification⁶ : H04L 7/033</p>	<p>A1</p>	<p>(11) International Publication Number: WO 97/41665</p> <p>(43) International Publication Date: 6 November 1997 (06.11.97)</p>
<p>(21) International Application Number: PCT/SE97/00665</p> <p>(22) International Filing Date: 18 April 1997 (18.04.97)</p> <p>(30) Priority Data: 9601640-7 29 April 1996 (29.04.96) SE</p> <p>(71) Applicant (for all designated States except US): TELEFONAKTIEBOLAGET LM ERICSSON (publ) [SE/SE]; S-126 25 Stockholm (SE).</p> <p>(72) Inventors; and (75) Inventors/Applicants (for US only): MOZETIC, Carlo [IT/IT]; Via G. Favretto, 9, I-00147 Roma (IT). TESTA, Francesco [IT/IT]; Piazza A. Moro, 22/C, I-00040 Pomezia (IT).</p> <p>(74) Agents: BANDELIN, Hans et al.; Telefonaktiebolaget LM Ericsson, Patent and Trademark Dept., S-126 25 Stockholm (SE).</p>		<p>(81) Designated States: AL, AM, AT, AU, AZ, BA, BB, BG, BR, BY, CA, CH, CN, CU, CZ, DE, DK, EE, ES, FI, GB, GE, GH, HU, IL, IS, JP, KE, KG, KP, KR, KZ, LC, LK, LR, LS, LT, LU, LV, MD, MG, MK, MN, MW, MX, NO, NZ, PL, PT, RO, RU, SD, SE, SG, SI, SK, TJ, TM, TR, TT, UA, UG, US, UZ, VN, YU, ARIPO patent (GH, KE, LS, MW, SD, SZ, UG), Eurasian patent (AM, AZ, BY, KG, KZ, MD, RU, TJ, TM), European patent (AT, BE, CH, DE, DK, ES, FI, FR, GB, GR, IE, IT, LU, MC, NL, PT, SE), OAPI patent (BF, BJ, CF, CG, CI, CM, GA, GN, ML, MR, NE, SN, TD, TG).</p> <p>Published With international search report. Before the expiration of the time limit for amending the claims and to be republished in the event of the receipt of amendments.</p>

(54) Title: D.T.R.M. DATA TIMING RECOVERY MODULE



(57) Abstract

A data timing recovery system for clock recovery based on a pulse generator circuit (106) and an injection locked oscillator (306) ILO, which extracts the clock signal at high rate and preserves the timing information during long "0" or "1" sequences. This system may also include a clock extractor circuit (102) including the ILO, a phase aligner circuit (104) and a clock killer circuit (108). Connections to and from the system are an incoming data link (110), an outgoing data link (122), an outgoing clock link (120), an enable/disable link (114) and a loss of signal data link (156). A data link (112) connected between the pulse generator circuit and the phase aligner circuit and to the clock killer circuit. A pulse link (116) connected to the ILO. A recovered clock link (118) connected between the clock extractor circuit and the phase aligner circuit.

FOR THE PURPOSES OF INFORMATION ONLY

Codes used to identify States party to the PCT on the front pages of pamphlets publishing international applications under the PCT.

AL	Albania	ES	Spain	LS	Lesotho	SI	Slovenia
AM	Armenia	FI	Finland	LT	Lithuania	SK	Slovakia
AT	Austria	FR	France	LU	Luxembourg	SN	Senegal
AU	Australia	GA	Gabon	LV	Latvia	SZ	Swaziland
AZ	Azerbaijan	GB	United Kingdom	MC	Monaco	TD	Chad
BA	Bosnia and Herzegovina	GE	Georgia	MD	Republic of Moldova	TG	Togo
BB	Barbados	GH	Ghana	MG	Madagascar	TJ	Tajikistan
BE	Belgium	GN	Guinea	MK	The former Yugoslav Republic of Macedonia	TM	Turkmenistan
BF	Burkina Faso	GR	Greece	ML	Mali	TR	Turkey
BG	Bulgaria	HU	Hungary	MN	Mongolia	TT	Trinidad and Tobago
BJ	Benin	IE	Ireland	MR	Mauritania	UA	Ukraine
BR	Brazil	IL	Israel	MW	Malawi	UG	Uganda
BY	Belarus	IS	Iceland	MX	Mexico	US	United States of America
CA	Canada	IT	Italy	NE	Niger	UZ	Uzbekistan
CF	Central African Republic	JP	Japan	NL	Netherlands	VN	Viet Nam
CG	Congo	KE	Kenya	NO	Norway	YU	Yugoslavia
CH	Switzerland	KG	Kyrgyzstan	NZ	New Zealand	ZW	Zimbabwe
CI	Côte d'Ivoire	KP	Democratic People's Republic of Korea	PL	Poland		
CM	Cameroon	KR	Republic of Korea	PT	Portugal		
CN	China	KZ	Kazakstan	RO	Romania		
CU	Cuba	LC	Saint Lucia	RU	Russian Federation		
CZ	Czech Republic	LI	Liechtenstein	SD	Sudan		
DE	Germany	LK	Sri Lanka	SE	Sweden		
DK	Denmark	LR	Liberia	SG	Singapore		
EE	Estonia						

D.T.R.M DATA TIMING RECOVERY MODULE**TECHNICAL FIELD OF THE INVENTION**

The present invention relates to a data timing recovery module
5 for clock recovery, more particular to clock extraction.

DESCRIPTION OF RELATED ART

Clock recovery is a well known method to recover timing on a
signalling link. The simplest way to send data on a serial
10 electrical link is to use two different physical connections,
one for data and one for timing, clock. One of the connections
can be avoided by extracting the timing information from the
data by means of a special code, for example CMI, HDB3, AMI
etc. By using one of these transmission codes, the normal data
15 bandwidth will be differently distributed and some high
frequency components will be generated. These components are
used to extract the timing information. This procedure is
called "clock recovery."

20 By using one of the previous codes the data bandwidth will be
enlarged. Because of that, it will be necessary to increase the
transmission media performance, and consequently more
expensive. This problem has been solved by using codes that
preserve the bandwidth characteristics, but the timing recovery
25 operation is more difficult. Circuits normally used for the
clock extraction need one or more data transitions every few
bit group, or the clock could not be extracted. The code used
must guarantee this condition, e.g. non-return to zero (NRZ)
scrambled data. The clock extraction problem is easily solved,
30 especially if the data pattern used is poor of transitions.

There are two existing methods to realize the clock extraction from an NRZ scrambled data link:

The first method consists of a narrow band phase locked loop (PLL), circuit with a digital phase comparator that
5 continuously measures the phase difference between the positive (or negative) data transition and the clock edges which are generated by a local oscillator. The frequency of this oscillator will be adjusted so as to eliminate the phase difference between data transitions and clock edges. This is an
10 expensive solution because often it is difficult to implement by standard discrete components. Furthermore, the flexibility is limited using this method because all the physical parameters such as frequency, pattern, etc. cannot be changed to cover other possible requirements.

15

The second method to extract the timing information consists of the application of a Q tank followed by a high gain selective amplifier stage. The Q tank is realized by a simple LC circuit, or by using a SAW resonator, continuously stimulated from data
20 edges transitions. If a LC resonator is used, a special inductor is needed in order to have a sufficiently large Q value to preserve the timing information during long "0" or "1" sequences. This is a more flexible solution, but it has lower performance than the one described previously. The recovered
25 clock, for example, is affected by jitter because the S/N ratio is very low at the Q tank output, especially if the pattern used is poor of transitions.

JP 88-174442 by Masushita et al, have an oscillator in free
30 running mode to guarantee a timing clock at the output **XXX**. The invention is to suppress the appearance of noise and jitter in

a periodical reproduction output, by obtaining a required timing clock based on self-advancing oscillation.

SUMMARY

5 One problem this invention solves is to extract a clock signal at high rate.

Another problem this invention solves is to preserve the timing information during long "0" or "1" sequences.

10

This invention solves the clock recovery problem in a new way by using a known effect which was originally used for another purpose. The purpose was for frequency modulation receivers, carrier modulation systems and to multiply or divide a clock
15 frequency by an integer number.

The present invention is a data timing recovery system, i.e. a data timing recovery module (DTRM), which is based on an injection locked oscillator, ILO. This invention extracts the timing
20 information from a high bit rate data signal, e.g. scrambled NRZ coming from optical or electrical interfaces. Other data patterns than NRZ can be used. The timing recovery system uses a lock-in phenomena in the ILO. The timing information will be extracted even if the data stream is composed by long sequences
25 of bit logic level "1" or by long sequences of bit logic level "0" repeatedly. At every data transition event, a zero crossing circuit generates a pulse which is used to phase lock the frequency generated by the oscillator.

30 This invention has at least two parts; the pulse generator circuit, and the injection locked oscillator. Other parts that

can be used are a clock extractor circuit including the ILO, a phase aligner circuit and a clock killer circuit.

One advantage is that the DTRM can extract time information
5 from high Mbit/s signals at a low cost.

Another advantage is that the DTRM can extract time information from high Mbit/s signals at high performance.

10 Another advantage is that the DTRM can be made to be very small in its dimensions.

Yet another advantage is that the DTRM is easy adaptable to different bit rate operation.

15

The invention is now being described further with the help of the detailed description of preferred embodiments and attached drawings.

20 BRIEF DESCRIPTION OF THE DRAWINGS

Figure 1 shows a block diagram of a data timing recovery module, DTRM.

Figure 2 shows a pulse generator circuit (PG).

Figure 3 shows a clock extractor circuit (CE).

25 Figure 4 shows a phase aligner circuit (PA).

Figure 5 shows a clock killer circuit (CK).

Figure 6a shows the block diagram of an ILO.

Figure 6b shows the working principle of the ILO.

Figure 7 shows a time relating flow chart for an incoming data
30 signal which goes into the DTRM, which produces phase aligned data and recovered clock signals.

Figure 8 shows a signal diagram over different signals in the DTRM.

Figure 9 shows an alternative embodiment of the DTRM.

5 DETAILED DESCRIPTION OF EMBODIMENTS

A more detailed description of the present invention will hereby be presented.

The present invention relates to a clock recovery circuit for
10 telecommunication equipment. This circuit can be used in other applications as well, where clock recovery is needed for high speed transmission links.

A short description of the drawings will be presented.

15 Figure 1 shows a block diagram of a data timing recovery module 100, DTRM. The four blocks include; a clock extractor circuit 102, CE, i.e. a pulse controlled oscillator circuit (PCO), a phase aligner circuit 104, PA, a pulse generator circuit 106, PG, and a clock killer circuit 108, CK. These blocks are
20 connected to each other by physical links. The data timing recovery module 100 has two incoming data links; the first incoming link being an incoming data link 110, carrying incoming data, connected to an incoming data link input 124, and the second incoming link being an enable/disable link 114,
25 carrying an external clock disable signal, connected to an incoming clock disable input 160. The DTRM 100 also has three outgoing links; the first outgoing link being an outgoing data link 122, carrying phase aligned data, connected to an outgoing data link output 126, the second outgoing link being an
30 outgoing clock link 120, carrying first recovered clock, connected to an outgoing clock link output 128, and the third

outgoing link being a loss of signal link 156, carrying a data loss signal, connected to a loss of signal output 158.

The pulse generator 106 has an incoming link being the incoming
5 data link 110, connected to an incoming data link input 130 via
the incoming data link input 124 of the DTRM 100. The pulse
generator 106 also has two output links; the first output link
being a pulse link 116, carrying pulses, connected between a
pulse link output 132 and to a pulse link input 136 of the
10 clock extractor 102, the second output link being a data link
112, carrying data, connected to a data link output 134 and to
a data link input 152 of the clock killer 108. The data link
112 is also connected to a data link input 148 of the phase
aligner 104.

15

The clock extractor 102 has two incoming links; the first
incoming link being the enable/disable link 114 connected to an
enable/disable link input 138 via the incoming clock disable
input 160 of the DTRM 100, and the second link being the pulse
20 link 116 connected to the pulse link input 136. The clock
extractor 102 also has two outgoing links; the first outgoing
link being a recovered clock link 118, carrying second
recovered clock, which can be inverted to the first recovered
clock on the outgoing clock link 120, connected to a clock link
25 output 142 and a clock link input 144 of the phase aligner 104,
and the second outgoing link being the outgoing clock link 120
connected to an outgoing clock link output 140 via the outgoing
clock link output 128 of the DTRM 100.

30 The phase aligner 104 has two incoming links; the first
incoming link being the recovered clock link 118 connected to

the clock link input 144, and the second incoming link being the data link 112 connected to the data link input 148. The phase aligner 104 has an outgoing link being the outgoing data link 122 connected to a phase aligner output 150 via the
5 outgoing data link output 126 of the DTRM 100.

The clock killer 108 has an incoming link being the data link 112. This circuit also has an outgoing link being the loss of signal link 156 connected to a loss of signal output 154 via
10 the loss of signal output 158 of the DTRM 100.

A more detailed description about each block in the data timing recovery module 100, DTRM, will be described in the next coming paragraphs. Only components that play a significant role in
15 each circuit are shown. This embodiment works with a differential data input and output links. The incoming data link 110, the data link 112 and the outgoing data link 122 are in reality two links which have one ordinary and one differential link. The invention does not require this, but it
20 is used in this solution.

In Figure 2, the pulse generator circuit 106 receives incoming data on the incoming data link 110 connected to the incoming data link input 130 via the incoming data link input 124 of the
25 DTRM 100. The pulse generator 106 sends out the pulses on the pulse link 116 connected between the pulse link output 132 and the pulse link input 136 of the clock extractor 102. In the pulse generator 106 contains two parts a zero crossing circuit 200 and a differential splitter 202. The differential splitter
30 202 is receiving the incoming data, on the incoming data link 110 to the zero crossing circuit 200. It sends out the pulses

on the pulse link 116. The differential splitter 202 also sends out the data, which is equal to the incoming data, on the data link 112 connected between the data link output 134 and the data link input 152 of the clock killer 108. The data link 112 is also connected to the data link input 148 of the phase aligner 104.

In Figure 3, the clock extractor circuit 102 receives pulses on the pulse link 116 connected between a pulse link input 136 and the pulse link output 132 of the pulse generator 106. The clock extractor 102 also contains an injection locked oscillator (ILO) 306 which has an oscillator input 308 and an oscillator output 304. The pulse link 116 is connected to the oscillator input 308 via the pulse link input 136. A clock extractor buffer 300 has two input links; first, a recovered clock link 302 connected to a first buffer input being a buffer input 312 and the oscillator output 304 of the ILO 306, and second, the enable/disable link 114 connected to the clock extractor buffer 300 via a second buffer input being a buffer input 310 and the enable/disable input 138. Optionally, the enable/disable link 114 can be connected externally to the loss of data signal link 156 to disable the clock in the case of no data on the incoming data link 110, see Fig. 1. The clock extractor buffer 300 has two outgoing links; first the outgoing link being the recovered clock link 118 connected to a first outgoing buffer output 314 via the clock link output 142, and second the outgoing buffer output being the outgoing clock link 120 connected to a second outgoing buffer output 316 via the outgoing clock link output 140.

The ILO 306 is an oscillator of a grounded base Colpitts architecture, Q1, e.g. a BFR92 transistor. The transistor Q1 bias point is fixed by using three resistors R1, R2 and R3. The resistors R1 and R2 determine the base voltage polarization and the resistor R3 determines the resistor collector current. A decoupling capacitor C2 is directly connected between the transistor Q1 base and the ground to obtain the dynamic grounded base architecture. The passive network, connected between the collector of the transistor Q1 and the positive power supply, determines all of the dynamic characteristics of this type of architecture which is called a "Grounded Base Colpitts Oscillator". In particular, capacitors C3, C4, C5 and inductance L1 determine the natural frequency of the oscillator 306, and resistor R4 is used to fix the transistor dynamic gain and also to increase the ILO 306 lock bandwidth. Reaction vector X_r is determined by the values of the two capacitors C3 and C4. Injection vector X_t is directly connected to the transistor emitter pin by using decoupling capacitor C1. The ILO 306 dynamic stability parameters depend also on the transistor type and on the electrical coupling of the ILO input and output. These are optimized in order to avoid frequency drift in the whole temperature operating range.

Figure 4 shows the phase aligner circuit 104 which gets data from the pulse generator 106 on the data link 112 which is connected between the data link input 148 of the phase aligner 104 and the data link output 134 of the pulse generator 106. The phase aligner 104 also receives the second recovered clock from the clock extractor 102, which is connected between the clock link output 142 of the clock extractor 102 and the clock link input 144 of the phase aligner 104. The phase aligner 104

emits phase aligned data from the phase aligner output 150 on to the outgoing data link 122 connected to the outgoing data link output 126 of the DTRM 100.

5 A D-flip-flop circuit 400 has two inputs; a first input 402 connected to the data link 112 via the data link input 148 of the phase aligner 106, and a second input 404 connected to the recovered clock link 118 via the clock link input 144 of the phase aligner 106. The flip-flop 400 has an output 406
10 connected to the outgoing data link 122 via the phase aligner output 150 of the phase aligner 106.

Figure 5, the clock killer circuit 108 receives data from the data link 112 connected between the data link input 152 of the
15 clock killer 108 and to the data link output 134 of the pulse generator 106. The clock killer 108 sends out the data loss signal on the loss of data link 156 which is connected to the loss of signal output 154 of the clock killer 108 and the loss of signal output 158 of the DTRM 100. The clock killer 108 has
20 three blocks; a peak detector (PD) 500, a voltage comparator (VC) 502 and a voltage reference (VR) 504. These blocks (500-504) are connected to each other by physical links. The data which comes in from the data link 112 which is connected to the peak detector 500. It is in its turn connected to the voltage
25 comparator 502. The VC 502 in its turn is connected to the loss of data link 156 via loss of signal output 154. The voltage reference 504 is connected to the voltage comparator 502.

Figure 6a shows a block diagram of the injection locked
30 oscillator 306. The ILO 306 has an incoming link being the pulse link 116 carrying the pulses, an injection $\overline{X}f$ signal 622,

connected between the oscillator input 308 of the ILO 306 and an adder node input 602 an adder node 318. The ILO 306 has an outgoing link being a recovered clock link 302 carrying a third recovered clock, a output vector \overline{Xu} signal 626, connected
5 between the oscillator output 304 of the ILO 306 and a selective amplifier output 608 at a selective amplifier 612. An adder node link 620 carrying a resultant \overline{Xi} signal 624 connected between an adder node output 604 of the adder node 318 and a selective amplifier input 632 of the selective
10 amplifier 612. Further, the recovered clock link 302 is connected to an attenuator input 618 at an attenuator 614. Therefore, the signal on the recovered clock link 302, the recovered clock link 118 and the outgoing clock link 120 is the same signal, see Fig. 1 and Fig. 3. An attenuation link 616
15 carrying a reaction \overline{Xr} signal 628 is connected between an attenuator output 630 of the attenuator 614 and an adder node input 606 of the adder node 318.

Figure 6b shows a vectorial diagram 600 of the signals, the
20 injection \overline{Xi} signal 622, the reaction \overline{Xr} signal 628 and the resultant \overline{Xi} signal 624, and their relations to each other.

Figure 7 shows a time related diagram over the method for extracting and aligning a clock signal and data from a combined
25 clock and data signal, the incoming data 802.

The method for clock recovery starts with a pulse generator stage 700. Then the incoming "DATA" 702 is received. Then, the pulse generator circuit 106 generates 704 the pulses. Further,
30 the pulse generator 106 divides 706 the incoming data.

Thereafter, the "pulses" 708 is distributed to a clock extractor stage 714 followed by distributing the "data" 710 to a phase aligner stage 742 and to a clock killer stage 754. As a last step the pulse generator stage 712 returns to 700, which
5 is equal to the block 712.

The clock extractor stage 714 has three different sequences. The first sequence being a clock recovery sequence, which begins with receiving "pulses" 716 from the pulse generator stage 700. Then the clock extraction stage 700 recovers 718 the
10 timing information in the ILO 306 with the help of the pulses. Thereafter, the second recovered "clock" 720 is distributed to "clock" 746 of the phase aligner stage 742 and the first recovered "CLOCK" 722 is also distributed to the outgoing clock
15 link 120. As a last step the clock extractor stage 724 returns to the block 714 is equal to the 724. The second sequence being a switching off clock sequence, which begins with the clock extractor stage 714 can also receive the external clock disable signal "OFF" 726 on the enable/disable link 114. Then the clock
20 extractor 102 turns off 728 clock extractor buffer 300 and turns off sending 730 the first and second recovered clock. As a last step clock extractor stage 732 returns to the block 714 which is equal to the block 732. The third clock sequence being a switching on clock sequence, which begins with switching on
25 the clock extractor stage also receives the external clock disable signal "ON" 734 on the enable/disable link 114. Then the clock extractor 102 turns on 736 the clock extractor buffer 300 and turns on sending 738 the first and second recovered clock. As a last step clock extractor stage 738 returns to the
30 block 714 which is equal to the block 738.

The phase aligner stage 742 receives "data" 744 from the pulse generator stage 700 and also receives second recovered "clock" 746 from the "clock" 720 of the clock extractor stage 714. Then these two signals are aligned, "alignment" 748. Thereafter, 5 phase aligned "DATA" 750 is sent out on the outgoing data link 122. As a last step phase aligner stage 752 returns to the block 742 which is equal to the block 752.

The clock killer stage 754 receives "data" 756 from the pulse 10 generator stage 700. Then, a question if there is any "data?" 758. If the answer is YES in 758, the data loss signal ON is sent 760 on the loss of signal link 156. If the answer is NO on the block 758 then an "alarm" 762 is notified. Further, the data loss signal OFF is sent 764 on the loss of signal link 15 156. As a last step from the blocks 760 and 764 this stage returns to clock killer stage 766 which is equal to 754.

Figure 8 shows a signal diagram over different signals at different points in the DTRM 100. This is an example of how 20 signals might appear in the DTRM 100. First a time ruler 800 shows signals at different time intervals. Incoming data 802 on the incoming data link 110 could have the following data pattern. A time interval is defined as the midpoint of positive derivative edge to negative derivative edges on a logic level 25 "1", or the other way around for a logic level "0". Negative pulses 804 coming from the pulse generator 106 on the pulse link 116 are generated at each time interval at every data transition logic level "1" by the zero crossing circuit 200. Data 806 is carried on the data link 112. Initially, an 30 external clock disable signal 808 is ON, e.g. logic level 1, on the enable/disable link 114. This means that the first

recovered clock 814 is carried on the outgoing lock link 120. If the external clock disable signal 808 OFF, e.g. logic level 0, the first recovered clock 814 is no longer carried on the outgoing lock link 120. In this case the second recovered clock 5 810 is no longer carried on the recovered clock link 118 and no phase aligned data will appear on the outgoing data link 122. ON/OFF can either be logic level "1"/"0" or logic level "0"/"1". When the external clock disable signal 808 is ON, the clock extractor 102 is already locked with the pulses 804 which 10 are sent to the clock extractor 102 from the pulse generator 106 through the pulse link 116. So, the phase aligner 106 is able to make the data re-aligned when the first positive second recovered clock edge is present on the recovered clock link 118. The data 806 coming on the data link 112 will be delayed 15 by a factor ψ . Phase aligned data 812 is carried on the outgoing data link 122. The second recovered clock 810, which is used to re-sample the data 806, can be inverted with respect to the first recovered clock 814, on the outgoing clock link 120. τ is the delay time between the initial bit presence at the 20 incoming data link 110 and the rise clock edge of the outgoing clock link 120 which is related to the same bit indicated previously.

Detailed description of the DTRM

25 Following will be a detailed description of the DTRM, which is a hybrid SIL circuit which could have the following dimensions: (41,2 x 10,6 x 0.6 mm). A four layer impedance controlled PCB (printed circuit board) has been used and all components are distributed on the two external layers. An external metal 30 shield has been used to prevent electromagnetic irradiation. It

is virtually connected to the ground, by using a decoupling capacitor.

This invention has been developed for two clock recovery operation frequencies, 184.320 MHz and 155.520 MHz. It can be used to extract the clock from NRZ scrambled data at different bit rates from 10 Mbit/s up to 500 Mbit/s. The DTRM 100 has been designed for the USI4 interfaces to extract the timing information from a serial data link properly coded. The DTRM can extract clock information for at least one data transition every 24 bits group. By using another value of variable inductor, the DTRM 100 can also be used to extract the timing information from the serial data link at 155.520 MHz properly coded in order to have at least one data transition every 24 bits group.

The data and clock I/O interfaces are differential emitter coupled logic (ECL). In case of positive power supply voltages differential pseudo emitter coupled logic (PECL) are used. The input interface can be serial or parallel. In PECL mode the output interfaces must not be shorted directly to the ground otherwise the output drivers could be damaged.

The pulse's polarity is one of the most important parameters because it determines the clock edge polarity. In order to respect the data setup and hold time, negative pulses are used for this embodiment, but positive pulses could be used.

The pulse generator circuit 106, Fig. 2, is implemented by the ECL differential splitter device 202. One of two the differential outputs is short circuited. At every data

transition event the zero crossing circuit 200 generates a pulse which is injected into the ILO 306 to lock-in phase a clock signal, the first recovered clock 814 and the second recovered clock 810. The pulse characteristic depends on the reaction times of the ECL differential splitter 202. In this case the pulse wave form on the same rise and fall times, to simplify the circuit architecture and to reduce the power consumption, but to increase the actual clock extraction performance of this application another type of wave form is recommended. This wave form should have a rise time slower than the actual choice in order to speed up the locked phase of the ILO 306 and to increase the lock bandwidth. The data link 112 is used to drive the phase aligner circuit 104.

The clock extractor 102, Fig. 3, uses the injection locked oscillator circuit 306, ILO, to extract timing information. The ILO 306 is realized only by an oscillator injected by a pulse at every data transition event. The pulses 804 are generated every data transition and synchronize the edge waveform produced by the oscillator. The pulse polarity determines the lock phase of the ILO 306. This embodiment is using the negative pulses 804 in order to synchronize the data negative edges with the clock negative ones. The data information is re-sampled in order to generate correct setup and hold time. The oscillator is a grounded base Colpitts architecture implemented by a transistor Q1, e.g. a BFR92, powered by a voltage regulator (3.6 V), not shown, to avoid frequency drift. The pulses 804 are directly injected to the adder node 318 via the emitter of the transistor Q1 by using the decoupling capacitor C1, see Fig. 3. During calibration of the oscillator the center frequency should be adjusted acting on a high performance

variable inductor implemented on the clock extractor 102 by using a data pattern which simulates the worst situation for the clock recovery operation. The oscillator output 304 is buffered 300 by a ECL line receiver-driver, e.g. clock extractor buffer 300, to regulate automatically a clock duty cycle.

The phase aligner circuit 104, Fig. 4, provides the data/clock phase alignment in order to have the negative second recovered clock 810 and the data 806 edges in a correct phase relation. This is done by a ECL differential D-flip-flop device which receives the data 806 information on the data link 112 coming from the pulse generator 106 and the second recovered clock 810 on the recovered clock link 118 coming from the clock extractor 102.

The clock killer circuit 108, Fig. 5, can give an alarm when not receiving the data 806 on the data link 112. This is implemented by the peak detector 500 connected to the voltage comparator 502 which has an open collector output stage. If the loss of data link 156 is connected to the enable/disable link 114, the clock killer 108 can switch OFF the clock extractor buffer 300, see Fig. 3, when the data 806 information is missing on the data link 112. This clock killer circuit 108 can also be used as a loss of data alarm. The connection to the clock extractor buffer 300 is external, so it can be removed if the clock extractor 102 must be left in free running mode. In this case the enable/disable link 114, see Fig. 1, must be connected to negative power voltage. The clock killer circuit 108 can also be used as the loss of signal alarm generator. The clock killer 108 can turn ON the clock extractor buffer 300

when the incoming data 802 is present. The clock extractor buffer 300 can be switched ON and OFF even if the enable/disable link 114 is not connected to the loss of data link 156 but connected to some other external unit which is not
5 shown in this embodiment.

The oscillation conditions in the ILO 306, in Fig. 6a, to extract clock signal are described by using two formulas:

$$10 \quad |\alpha\beta| \geq 1, \quad \angle \bar{\alpha}\bar{\beta} \cong 0$$

The first formula shows the relation between the selective amplifier gain 612 and the attenuator 614 of the reaction network. The second formula shows the phase relation needed to
15 start the ILO 306 oscillation. In this situation the ILO 306 can be considered a free running oscillator and its frequency depends only on the physical parameters of the selective amplifier 612 and it should be set by acting on the variable inductor L1, Fig. 3. To perform the injection locked effect the
20 adder node 318 is needed. It consists of an analog mixer which is used to mix the synchronized pulses the injection \bar{X}_i signal 622 with a reaction \bar{X}_r signal 628 of the oscillator.

These formulas are obtained from the transfer function of this
25 architecture:

$$\bar{\alpha} = \frac{\bar{X}_u}{\bar{X}_i}; \quad \bar{\beta} = \frac{\bar{X}_r}{\bar{X}_u} \quad \rightarrow \quad \bar{X}_u = \bar{\alpha} \bar{X}_i; \quad \bar{X}_r = \bar{\beta} \bar{X}_u$$

$$\text{but } \overline{Xt} = \overline{Xi} - \overline{Xr} \text{ and } \overline{Ar} = \frac{\overline{Xu}}{\overline{Xi}} \rightarrow \overline{Ar} = \frac{\overline{\alpha} \overline{Xi}}{\overline{Xi} - \overline{Xr}}$$

$$\text{so } \overline{Ar} = \frac{\overline{\alpha} \overline{Xi}}{\overline{Xi} - \overline{\alpha} \overline{\beta} \overline{Xi}} = \frac{\overline{\alpha}}{1 - \overline{\alpha} \overline{\beta}} \quad (1) \quad \left\{ \begin{array}{l} \angle \overline{\alpha} \overline{\beta} = 0 \\ |\overline{\alpha} \overline{\beta}| \geq 1 \end{array} \right. \quad (2)$$

5 were \overline{Ar} is a function of the ILO 306. The condition (1) is applicable only if $|\overline{\alpha} \overline{\beta}| < 1$. In the other situations the poles analysis must be considered in the transfer function (1). There are three possible conditions: $|\overline{\alpha} \overline{\beta}| < 1$, $|\overline{\alpha} \overline{\beta}| = 1$, $|\overline{\alpha} \overline{\beta}| > 1$. The condition $|\overline{\alpha} \overline{\beta}| = 1$ is also called the Barkhausen condition and it
 10 represents the stability limit. Above this limit ($|\overline{\alpha} \overline{\beta}| > 1$) the ILO 306 starts to oscillate with an oscillation period that satisfies the condition in (2).

In Fig. 6b is shown the vectorial diagram 600 of the
 15 oscillation condition of the two input signals in the adder node 318. The pulse's polarity determines the locked phase of the oscillator. In this case it is needed to re-establish the correct phase alignment between the data and the second recovered clock at the output time. In this embodiment the
 20 negative pulses 804 are used in order to synchronize the data's negative edges with the clock's negative ones. The reaction \overline{Xr} signal 628 is a cycling vector with the same phase as of the output vector \overline{Xu} signal 626, Fig. 6a. If another reaction vector is injected in the adder node 318 the situation in Fig.
 25 6b will occur. The reaction \overline{Xr} signal 628 is represented by a rotating vector and it has a rotation period T_1 , which is the

inverse of the frequency generated by the oscillator. The resultant $\overline{X_i}$ signal 624 depends on the amplitude and the phase parameters of the other two the reaction $\overline{X_r}$ signal 628 and the injection $\overline{X_t}$ signal 622.

5

Normally in the block diagram of an oscillator the injection $\overline{X_t}$ signal 622 does not appear because the oscillation can start without it. The adder node 318 also does not appear because the reaction $\overline{X_r}$ signal 628 and the resultant $\overline{X_i}$ signal 624 are the
10 same parameter. This invention wants to lock the oscillator with the pulses 804 generated at every data transition by using the adder node 318 to make a vectorial sum of the reaction $\overline{X_r}$ signal 628 with the pulses 804, the injection $\overline{X_t}$ signal 622 injected through the pulse link 116.

15

If the injection $\overline{X_t}$ signal 622 is applied at the adder node 318 we obtain the situation showed in Fig. 6b. The resultant $\overline{X_i}$ signal 624 will be affected by an instantaneous phase jump and also its amplitude will change. If the injection $\overline{X_t}$ signal 622
20 is constituted of the pulses 804 which have a period T_2 about a multiple m of the natural period T_1 of the oscillator and if the amplitude of these pulses are comparable with the amplitude of the reaction $\overline{X_r}$ signal 628, the oscillator will be locked in phase to the T_2 period. The injection $\overline{X_t}$ signal 622 can be
25 constituted by the incoming data 802 and will lock-in phase the same way as the pulses 804.

If $|\overline{Xr}| > |\overline{Xi}|$, the resultant \overline{Xi} signal 624 is more affected by the reaction \overline{Xr} signal 628 parameters. This also means that the injection \overline{Xi} signal 622 does not produce relevant effects on the output vector \overline{Xu} signal 626, so it could cause only jitter
5 at the oscillator output if the injection \overline{Xi} signal 622 frequency and the normal frequency of the oscillator are different. This means that the locking bandwidth of the ILO 306 is dependent on the magnitude $|\overline{Xi}|$ of the injection \overline{Xi} signal 622. The stronger the injection \overline{Xi} signal 622 the larger the
10 locking bandwidth.

If vector $|\overline{Xi}| = |\overline{Xr}|$ both of these components have the same effect on the resultant \overline{Xi} signal 624. If the injection \overline{Xi} signal 622 and the reaction \overline{Xr} signal 628 have the same
15 frequency and if the vectorial sum of them generate the resultant \overline{Xi} signal 624 with enough energy, the oscillation condition will be reestablished. This is true also if the normal frequency of the oscillator and the frequency of the injection \overline{Xi} signal 622 are nearly but not exactly the same,
20 because the ILO 306 is looped back, thus the reaction \overline{Xr} signal 628 depends also from the injection \overline{Xi} signal 622. If the injection \overline{Xi} signal 622 frequency is contained inside the amplifier bandwidth the resultant \overline{Xi} signal 624 will follow the injection \overline{Xi} signal 622 and the oscillation period will be
25 locked by the injection \overline{Xi} signal 622 frequency.

If the injection \overline{X}_i signal 622 is switched off for a time of more than one period, the oscillator will be still active because the oscillation is guaranteed by the reaction \overline{X}_r signal 628. During these periods the phase difference between the
5 reaction \overline{X}_r signal 628 and missing the injection \overline{X}_i signal 622 will increase, but when the injection \overline{X}_i signal 622 is switched on again the resultant \overline{X}_i signal 624 will be affected by a phase jump. The previous lock-in situation will be re-established provided that the phase jump is not be so large as
10 to generate intermodulation products distributed out of the amplifier bandwidth. The same situation can be obtained if the injection \overline{X}_i signal 622 is an instantaneous vector pulse sometimes inserted in the adder node input 602, but its magnitude must be larger than the reaction \overline{X}_r signal 628
15 ($|\overline{X}_i| > |\overline{X}_r|$), see Fig. 6b, in order to generate a relevant harmonic product contained into the amplifier bandwidth. If this happens the oscillator could generate a signal not related to any of the two vectors.

20 The limits of frequencies for locking pulses depend on the amplitudes of the injection \overline{X}_i signal 622 and the reaction \overline{X}_r signal 628, on the frequency relation between them, and on the Q factor of the LC resonator, see Fig. 3, implemented in the oscillator. The frequency relation between the reaction \overline{X}_r
25 signal 628 and the injection \overline{X}_i signal 622 must be an integer number, and it could be a time variable. The data transitions are time variable too, so they can synchronize the oscillator.

Detailed description of the method

The method for using this kind of circuit will now be described. External incoming signals are independent of each other and can come in at any time and internal signals can be
5 independently received at any time. This embodiment needs the clock extractor stage 714. If desired, the pulse generator stage 700, the phase aligner stage 742 and the clock killer stage 754 can be used.

10 The method for clock recovery starts with the pulse generator stage 700, see Fig. 7. The incoming data 802 is received 702 on the incoming data link 110 to the pulse generator 106 via the incoming data link input 130 of the pulse generator 106. Then at every data transition event the zero crossing circuit 200
15 generates 704 the negative pulse 804. Further the differential splitter 202 divides 706 the incoming data 802 into the data 806 and the pulses 804. Thereafter, the pulse generator stage 700 distributes 708 the pulses 804, to the clock extractor 102 on the pulse link 116. Further stage 700 also distributes 710
20 the data 806 on the data link 112 to the phase aligner 104. The pulse generator 106 can also distribute 710 the data 806 on the data link 112 to the clock killer circuit 108.

In the clock extractor stage 714 the clock recovery sequence
25 starts with receiving 716 the negative pulses 804 from the pulse generator stage 700. This clock recovery sequence recovers 718 the timing information from the pulses 804 generated by the pulse generator 106, see Fig 6a-b. Thereafter, the clock recovery sequence distributes 720 the second
30 recovered clock 810 to the phase aligner stage 742. The clock

extractor 102 also distributes 722 the first recovered clock 814 to the outgoing clock link 120.

The clock extractor stage 714 can be in disabled mode or in
5 normal mode. If the loss of signal link 156 and the enable/disable link 114 are connected to each other which would result in that external clock disable signal 808 and the data loss signal being equal to each other.

10 The disabled mode is equal to the switching off sequence in the clock extractor stage 714. In case of an external alarm, i.e. from the clock killer stage 754, the clock extractor buffer 300 can be disabled when receiving 726 the external clock disable
15 signal 808 OFF on the external enable/disable link 114. This will switch off clock sequence and switch OFF the clock extractor buffer 300 to disable mode. This sequence will also close 728 the clock extractor buffer 300 and turned off 730 the sending of the first recovered clock 814 to the outgoing clock link 120 and to the second recovered clock 810 to the phase
20 aligner stage 742. Thereafter, the switching off clock sequence returns to clock extractor stage 714.

The normal mode is equal to switching on clock sequence in the clock extractor stage 714. In case of the alarm being switched off, the clock killer stage 754 can put the clock extractor
25 buffer 300 back to normal mode. This is done when receiving 734 the external clock disable signal 808 ON, on the external enable/disable link 114. This will switch on clock sequence and open the clock extractor buffer 300 to normal mode. The second recovered clock 810 is turned on 736 by opening the clock
30 extractor buffer 300. This sequence can also turn on 738

sending the first recovered clock 814 to the outgoing clock link 120 and the second recovered clock 810 to the phase aligner stage 742. Thereafter, the switching on clock sequence returns to the clock extractor stage 714.

5

The phase aligner stage 742 receives 744 the data 806 from the pulse generator stage 700 and receives 746 the second recovered clock 810 from the clock extractor stage 714. Then, these two signals are aligned 748. When alignment is done, phase aligned data 812 is sent out 750 on the outgoing data link 122. Followed by the phase aligner stage 752 which is equal to the block 742.

The clock killer stage 754 is not necessary for the invention but is useful as an alarm feature when the incoming data 802 are not present. This stage 754 receives 756 the data 806 from the pulse generator stage 700. Then, a question is whether there is any "data?" 758. If the answer is YES in the 758 the external clock disable signal ON is sent out 760. If the answer is NO in the block 758 then an alarm is sent 762. Further, the external clock disable signal OFF is sent out 764. From the blocks 760 and 764 this stage ends with the clock killer stage 760 which is equal to the block 754.

25 Alternative embodiments

In figure 9 is shown an alternative time recovery system 900 which includes the pulse generator circuit 106 and the injection locked oscillator 306. The incoming data link 110 is connected to the pulse generator circuit 106. This circuit only has to be connected to the pulse link 116. The pulse link 116 is connected to the injection locked oscillator 306 at the

30

oscillator input 308. The recovered clock link 302 is connected between the injection locked oscillator 306 at the oscillator output 304 and the outgoing clock link output 128. The recovered clock link 302 is equal to the outgoing clock link
5 120, see Fig. 1.

Another alternative time recovery system can be that, instead of the injection locked oscillator 306, the clock extractor circuit 102 is installed. The pulse link 116 and the recovered
10 clock link 118 is connected in the same way as in Fig. 1.

An alternative time recovery system does not need to have the clock extractor buffer 300 in the clock extractor circuit. Therefore, the alternative system does not need to have the
15 enable/disable link 114, the outgoing data link 120 and internal external connections belonging to these links.

Alternative embodiment will lie in the same range from just the pulse generator circuit 106 and the injection locked oscillator
20 306 to all circuits, parts, and components which are described in Fig. 1.

Alternative methods follow the physical condition of the time recovery system. If only the injection locked oscillator 306 and the pulse generator 106 are used. The method only includes
25 parts of the pulse generator stage 700 and the clock extractor stage 714. These stages will receive the incoming data 802 to the pulse generator 106. Then sending the generated pulses 804 to the ILO 306. Followed by recovering the first recovered
30 clock and thereafter sending the first recovered clock 814 onto the outgoing clock link 120.

In another method where the clock killer circuit 108 is not present then the clock killer stage 754 is not present. If just the injection locked oscillator 306 is present then the clock extractor stage 714 does not have the steps 726 until the step
5 740.

All methods will follow the physical conditions which are described above. If there is no clock killer circuit there can not be any clock killer stage 754 and so on.

10

The invention described above may be embodied in yet other specific forms without departing from the spirit or essential characteristics thereof. Thus, the present embodiments are to be considered in all respects as illustrative and not
15 restrictive, the scope of the invention being indicated by the appended claims rather than by the foregoing descriptions, and all changes which come within the meaning and range of equivalency of the claims are therefore intended to be embraced therein.

CLAIMS

1. A data timing recovery system for clock recovery, c h a -
r a c t e r i z e d by the data timing recovery system (100)
5 comprising: a pulse generator circuit (106) and an injection
locked oscillator (306); the system being connected to an
incoming data link (110), and an outgoing clock link (120); the
pulse generator being connected to the incoming data link, and
to the injection locked oscillator, where the pulse generator is
10 generating a pulse at every data transition event hence forming
a flow of pulses 804 to the injection locked oscillator; the
injection locked oscillator utilizes the pulses to phase lock
its frequency, said oscillator being connected to the outgoing
link sending out first recovered clock (814).

15

2. The data timing recovery system for clock recovery according
to claim 1, c h a r a c t e r i z e d by the data timing
recovery system (100) comprising: the pulse generator circuit
(106) including a zero crossing circuit (200), and a
20 differential splitter (202), these two components being
connected to each other; the differential splitter being
connected to the incoming data link (110), and being connected
to a pulse link (116), said pulse link being connected to the
injection locked oscillator (306).

25

3. The data timing recovery system for clock recovery according
to claim 2, c h a r a c t e r i z e d by the differential
splitter being connected to a data link (112).

30 4. The data timing recovery system for clock recovery according
to claim 2 or 3, c h a r a c t e r i z e d by the data timing

recovery system (100) comprising: a clock extractor (102) including the injection locked oscillator (306), and a clock extractor buffer (300), these two components being connected to each other by a recovered clock link (302); the clock extractor
5 buffer (300) being connected to the outgoing clock link (120).

5. The data timing recovery system for clock recovery according to claim 4, characterized by the clock extractor buffer (300) being connected to an enable/disable link (114).

10

6. The data timing recovery system for clock recovery according to claim 3, characterized by the data timing recovery system (100) comprising: a phase aligner circuit (104) being connected to the clock extractor (102) via a recovered
15 clock link (118); the phase aligner circuit being connected to the pulse generator circuit (106) via the data link (112), and said phase aligner circuit being connected to an outgoing data link (122).

20 7. The data timing recovery system for clock recovery according to claim 3, characterized by the data timing recovery system (100) comprising: a clock killer circuit (108) being connected to the pulse generator circuit (106) via the data link (112), and the clock killer circuit being connected to
25 a loss of signal link (156).

8. The data timing recovery system for clock recovery according to claims 5 and 7, characterized by the loss of signal link (156) being connected to the enable/disable link
30 (114).

9. A method for clock recovery in a data timing recovery system, characterized by first a pulse generator stage (700) comprising the steps of: receiving (702) incoming data (802), generating (704) pulses (804) at every data transition event, 5 sending (708) the pulses to a clock extractor stage (714), and returning (712) to the pulse generator stage (700); and second the clock extractor stage (714) being a clock recovery sequence comprising the steps of: receiving (716) the pulses from the pulse generator stage (700), recovering (718) a second recovered 10 clock signal (810) with the help of the pulses, sending (722) out a first recovered clock (814) to an outgoing clock link (120), and returning (724) to the clock extractor stage (714).

10. The method according to claim 9, characterized 15 by the pulse generator stage (700) further comprising the steps of: dividing (706) incoming data (802) to the pulses (804) and to data (806), and sending (710) the data (806) to a phase aligner stage (742).

20 11. The method according to claim 10, characterized by the pulse generator stage (700) further comprising the step of sending (710) the data (806) to a clock killer stage (754).

25 12. The method according to claim 9, characterized by the clock extractor stage (714) further comprising the step of distributing (720) the second recovered clock (810) to the phase aligner stage (742).

30 13. The method according to claims 10 and 12, characterized by the phase aligner stage (742) comprising the steps of: receiving the data (806) from the pulse generator

stage (700), receiving (746) the second recovered clock (810) from the clock extractor stage (714), aligning (748) the data and the second recovered clock which results in phase aligned data (812), sending out (750) the phase aligned data on the outgoing data link (122), and returning (752) to phase aligner stage (742).

14. The method according to claim 11, characterized by a clock killer stage (754) comprising the steps of: when receiving (756) the data (806) from the pulse generator stage (700), sending (760) out a data loss signal ON on a loss of signal link (156), and returning (766) to the clock killer stage (754).

15. The method according to claim 11, characterized by a clock killer stage (754) comprising the steps of: when not receiving (756) the data (806) from the pulse generator stage (700) setting alarm, sending out a data loss signal OFF on a loss of signal link (156), and returning (766) to the clock killer stage (754).

16. The method according to claim 9, characterized by the clock extractor stage (714) being a switching off sequence comprising the steps of: receiving (726) an external clock disable signal (808) OFF on a external enable/disable link (114), switching (728) a clock extractor buffer (300) to disable mode, closing the clock extractor buffer, turning OFF (730) the clock extractor buffer whereby the sending of first recovered clock (814) being turned off from the outgoing clock link (120), and returning (732) to the clock extractor stage (714).

17. The method according to claims 12 and 16, characterized by the clock extractor stage (714) further comprising the step of turning off (730) the sending the second recovered clock (810) to the phase aligner stage (742).

5

18. The method according to claim 9, characterized by the clock extractor stage (714) being a switching on sequence comprising the steps of: receiving (734) an external clock disable signal (808) ON on a external enable/disable link (114),
10 switching (736) the clock extractor buffer (300) to normal mode, opening the clock extractor buffer, turning ON (738) the clock extractor buffer 300 thereby initiating sending of the first recovered clock (814) being turned on from the outgoing clock link (120), and returning (740) to the clock extractor stage
15 (714).

19. The method according to claims 12 and 18, characterized by the clock extractor stage (714) further comprising the step of turning on (738) the sending of the second recovered
20 clock (810) to the phase aligner stage (742).

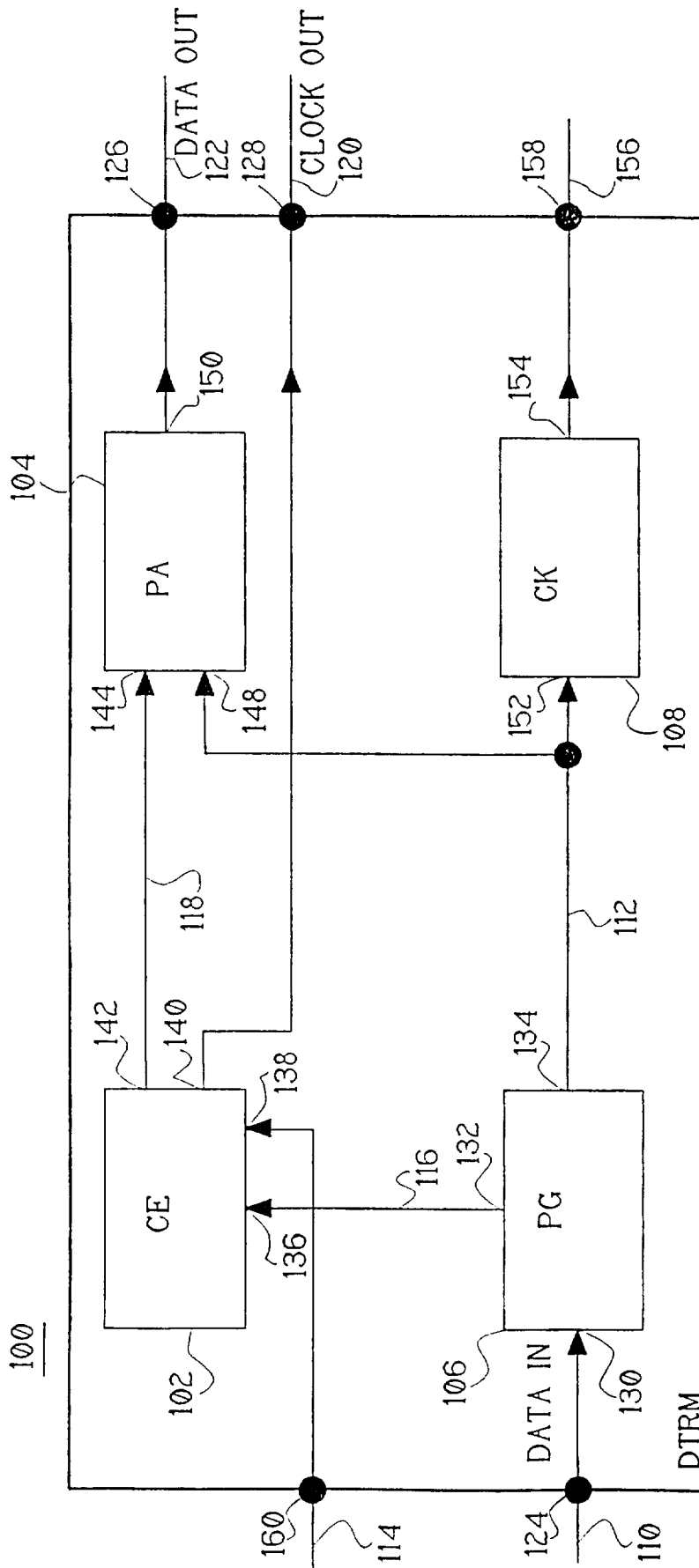

Fig. 1

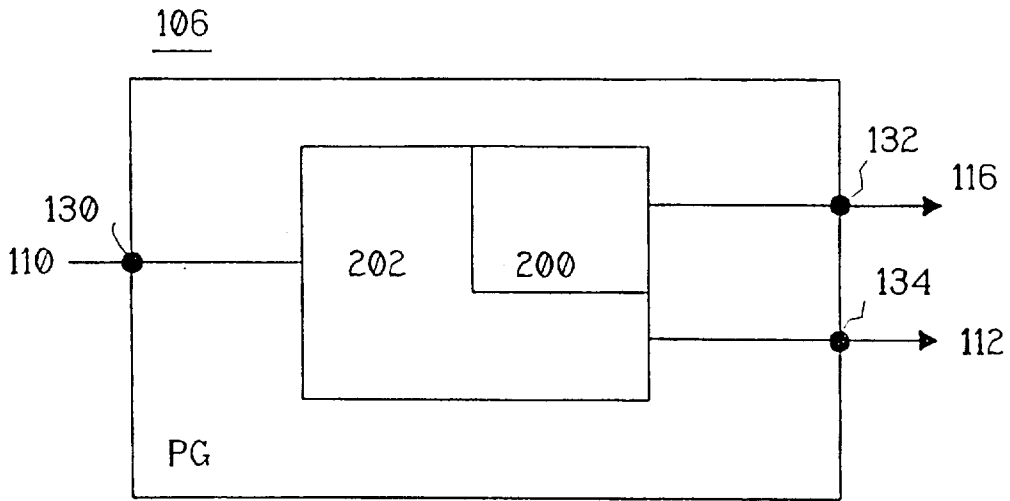

Fig. 2

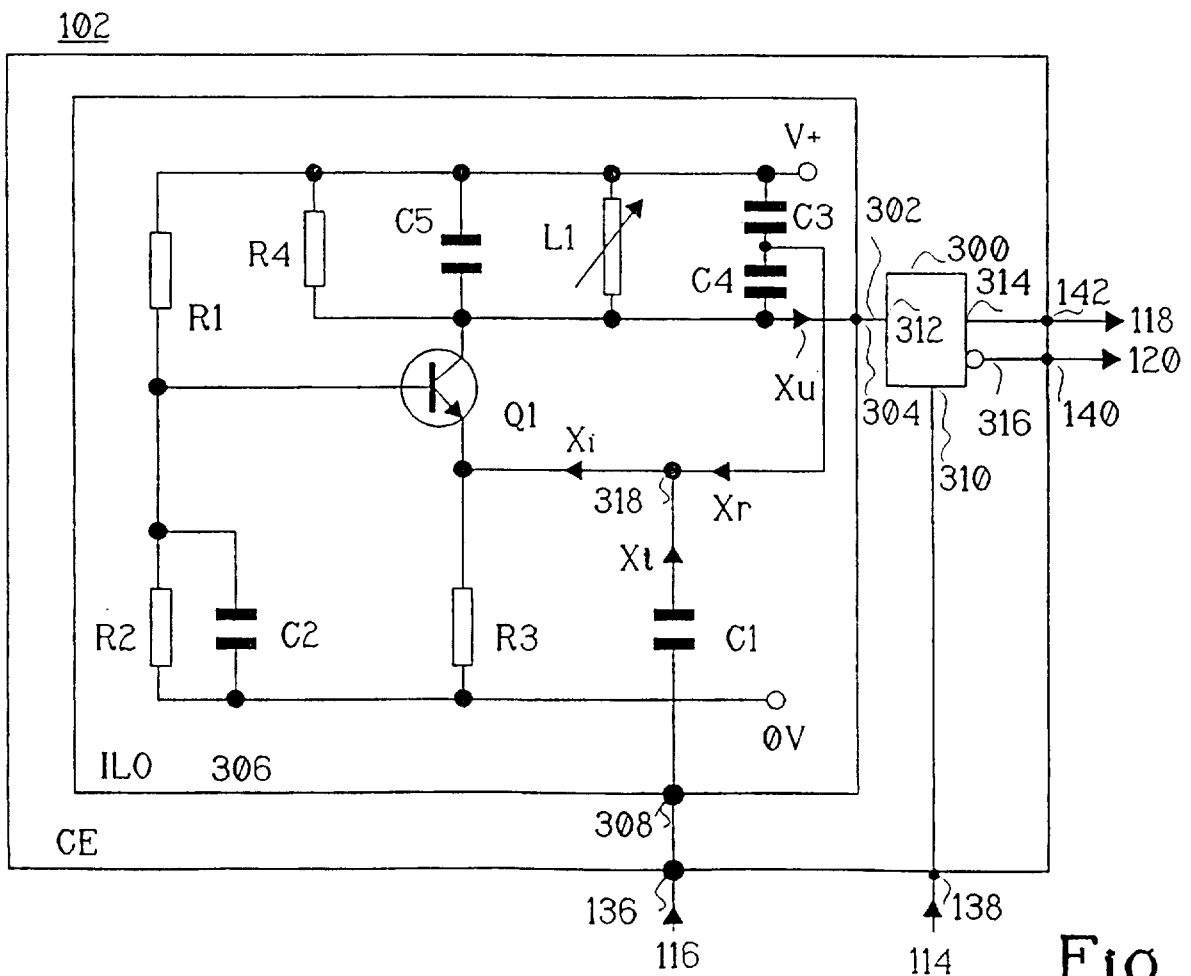

Fig. 3

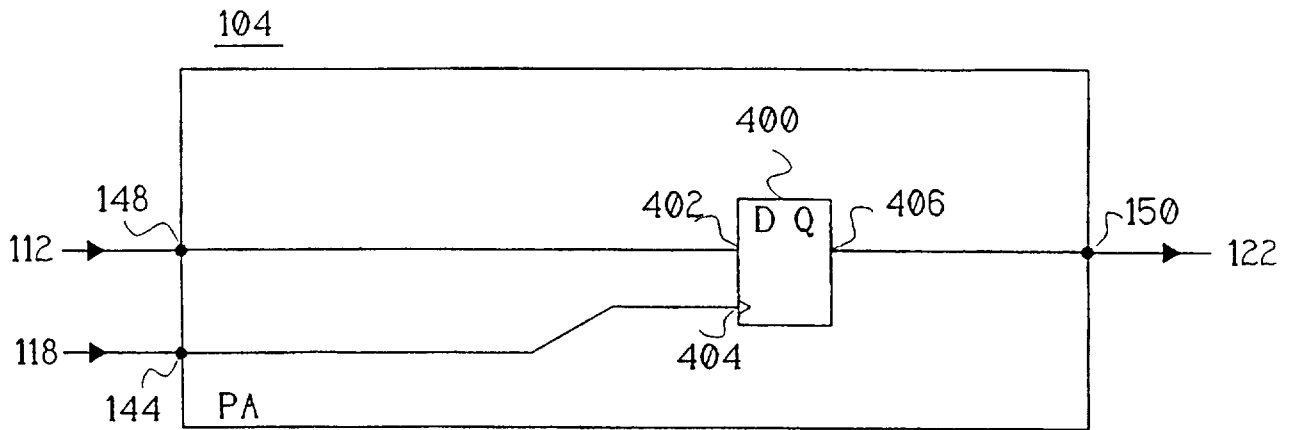

Fig. 4

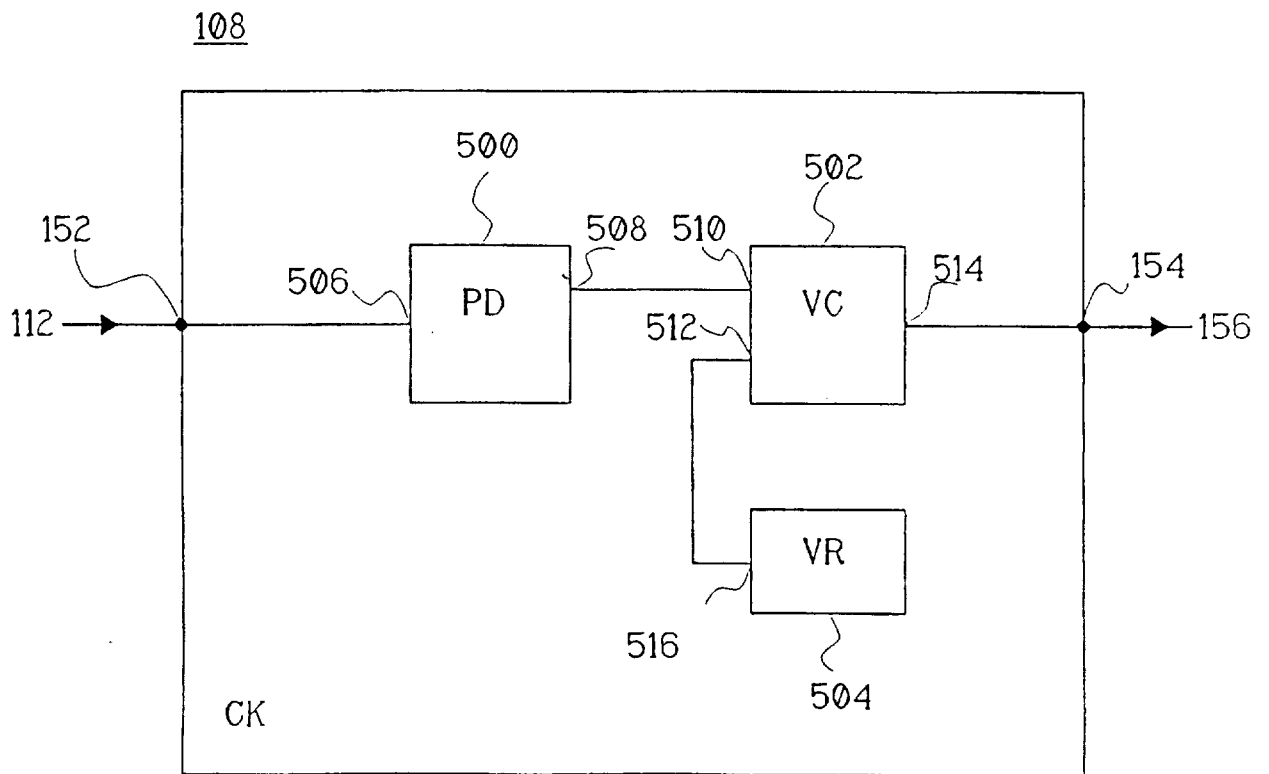

Fig. 5

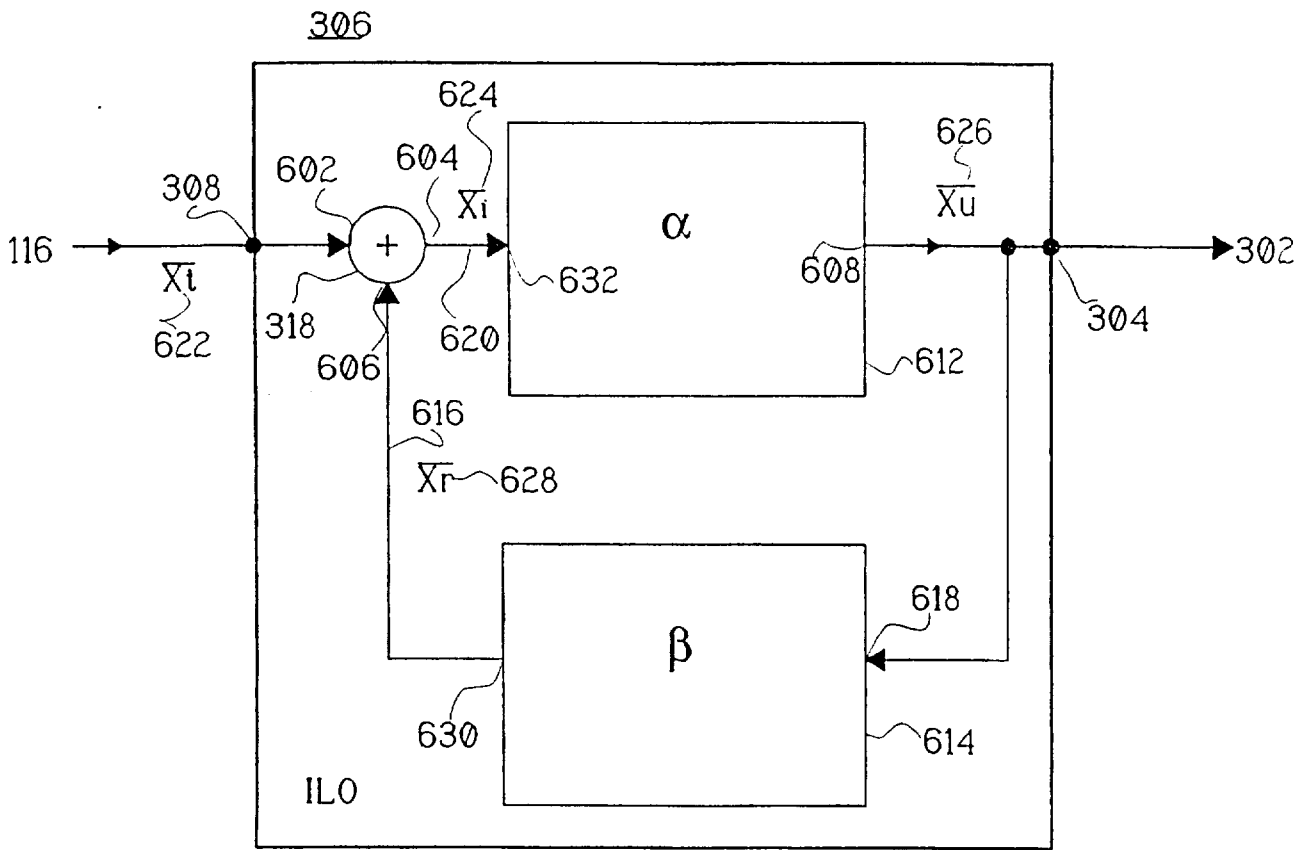

Fig. 6a

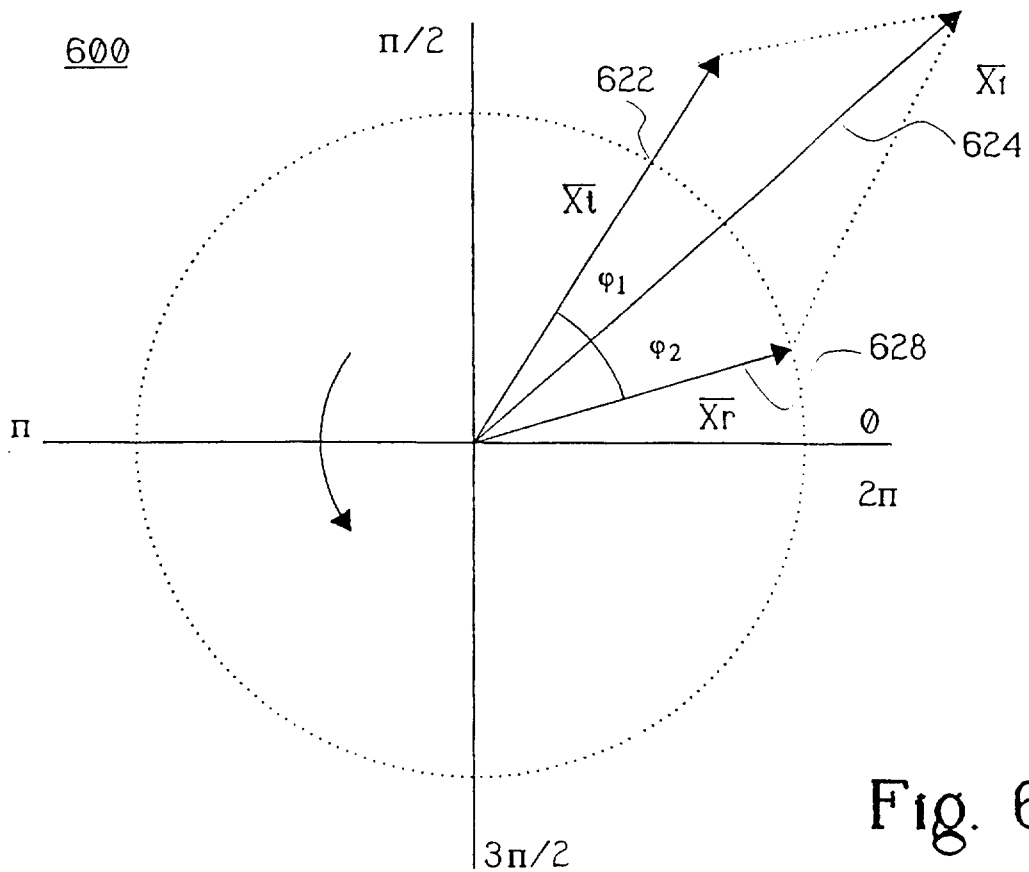

Fig. 6b

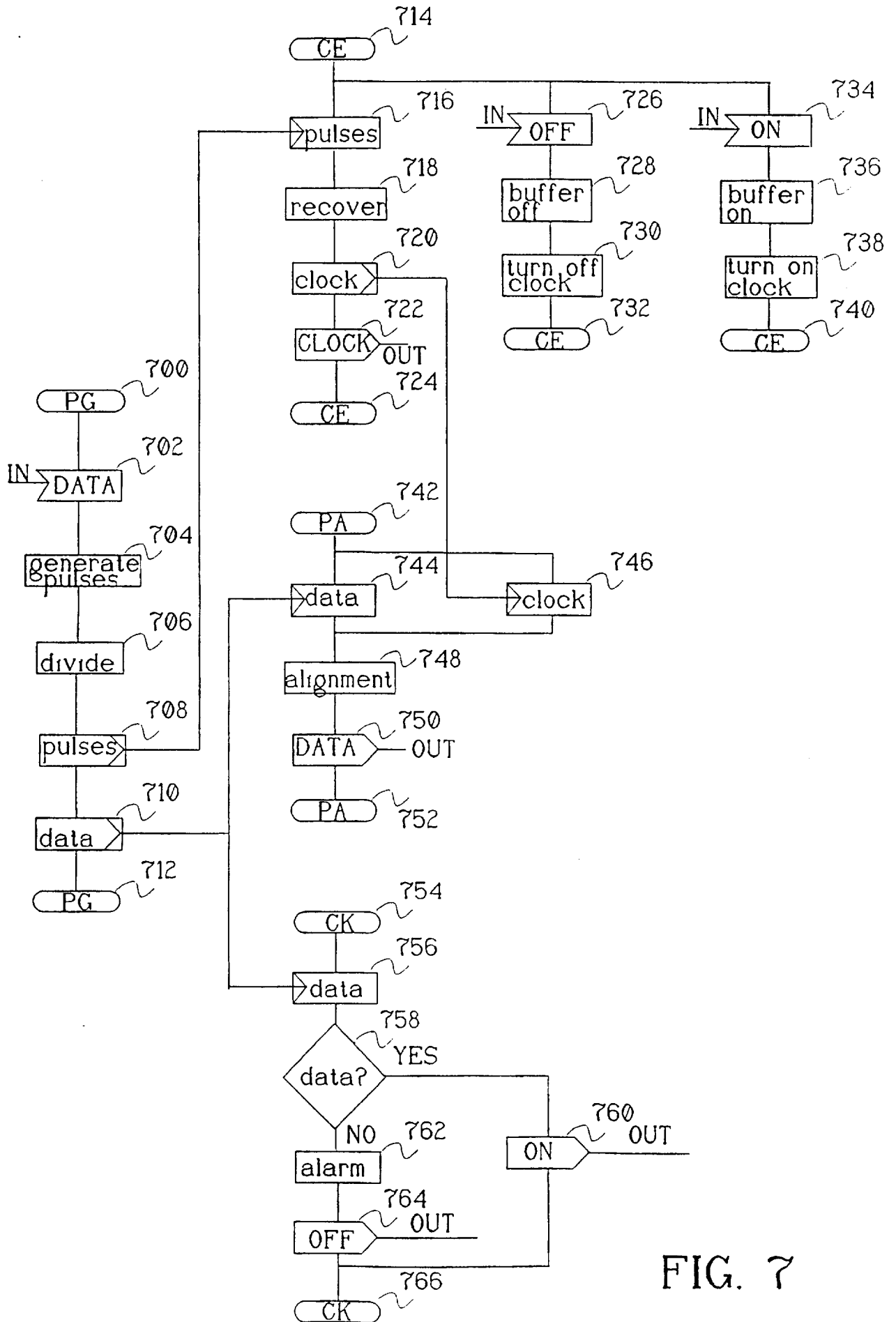

FIG. 7

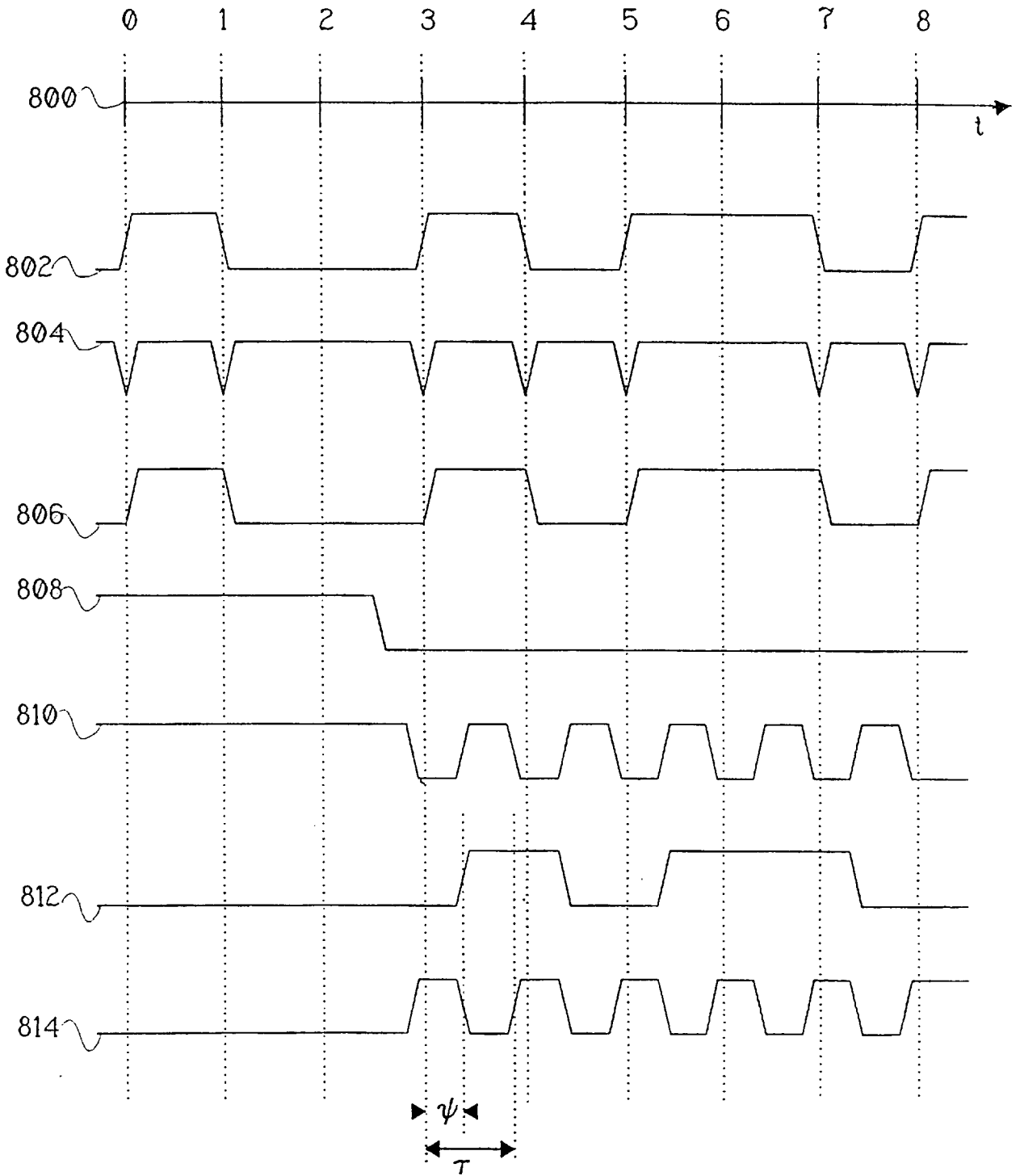

Fig. 8

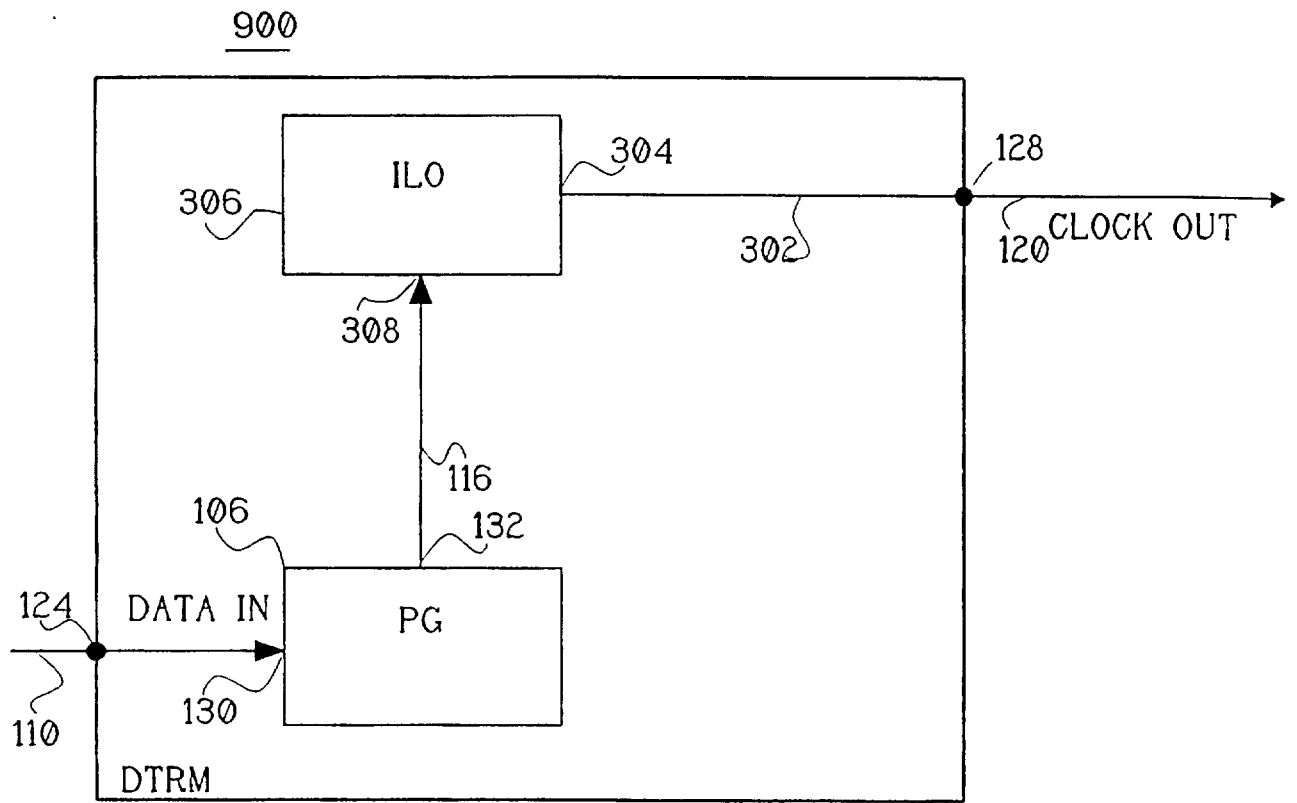

Fig. 9

INTERNATIONAL SEARCH REPORT

International application No.
PCT/SE 97/00665

A. CLASSIFICATION OF SUBJECT MATTER

IPC6: H04L 7/033
According to International Patent Classification (IPC) or to both national classification and IPC

B. FIELDS SEARCHED

Minimum documentation searched (classification system followed by classification symbols)

IPC6: H04L, H04J

Documentation searched other than minimum documentation to the extent that such documents are included in the fields searched

SE,DK,FI,NO classes as above

Electronic data base consulted during the international search (name of data base and, where practicable, search terms used)

EDOC, JAPIO

C. DOCUMENTS CONSIDERED TO BE RELEVANT

Category*	Citation of document, with indication, where appropriate, of the relevant passages	Relevant to claim No.
Y	US 5276712 A (JONATHAN D. PEARSON), 4 January 1994 (04.01.94), column 5, line 49 - line 59, figure 1	1,9
A	--	2-8,10-19
Y	US 5050167 A (HOSSEIN IZADPANAH), 17 Sept 1991 (17.09.91), column 5, line 32 - line 55, figure 7	1,9
A	--	2-8,10-19
A	Patent Abstracts of Japan,, abstract of JP,A, 7-143200 (MATSUSHITA ELECTRIC INC CO LTD), 2 June 1995 (02.06.95)	1-19

Further documents are listed in the continuation of Box C.

See patent family annex.

* Special categories of cited documents:

"A" document defining the general state of the art which is not considered to be of particular relevance

"E" earlier document but published on or after the international filing date

"L" document which may throw doubts on priority claim(s) or which is cited to establish the publication date of another citation or other special reason (as specified)

"O" document referring to an oral disclosure, use, exhibition or other means

"P" document published prior to the international filing date but later than the priority date claimed

"T" later document published after the international filing date or priority date and not in conflict with the application but cited to understand the principle or theory underlying the invention

"X" document of particular relevance: the claimed invention cannot be considered novel or cannot be considered to involve an inventive step when the document is taken alone

"Y" document of particular relevance: the claimed invention cannot be considered to involve an inventive step when the document is combined with one or more other such documents, such combination being obvious to a person skilled in the art

"&" document member of the same patent family

Date of the actual completion of the international search

25 August 1997

Date of mailing of the international search report

26 -08- 1997

Name and mailing address of the ISA/
Swedish Patent Office
Box 5055, S-102 42 STOCKHOLM
Facsimile No. +46 8 666 02 86

Authorized officer

Anders Ströbeck
Telephone No. +46 8 782 25 00

INTERNATIONAL SEARCH REPORT
Information on patent family members

06/08/97

International application No.

PCT/SE 97/00665

Patent document cited in search report	Publication date	Patent family member(s)	Publication date
US 5276712 A	04/01/94	AU 6896191 A CA 2045166 A EP 0453557 A JP 4505239 T WO 9107832 A	13/06/91 17/05/91 30/10/91 10/09/92 30/05/91
US 5050167 A	17/09/91	NONE	