

Eseguito - Prepared	Resp. del contenuto - Subj. resp.	No.	1911-ROJ21213/1 Ux
TH/A C. Mozetic	-	Data - Date	1993-10-27 Pa2
Resp. del documento/Approvato - Doc. respons/Approved	TH/A A. Putorti	Rev.	-
Denominazione		Title	
ATM CLOCK BOARD		PRINTED BOARD ASSEMBLY	
Tolleranze - Tolerances		Regole di disegno - Drawing rules	
		Rif. - Ref.	

TP FROM 0 TO 20

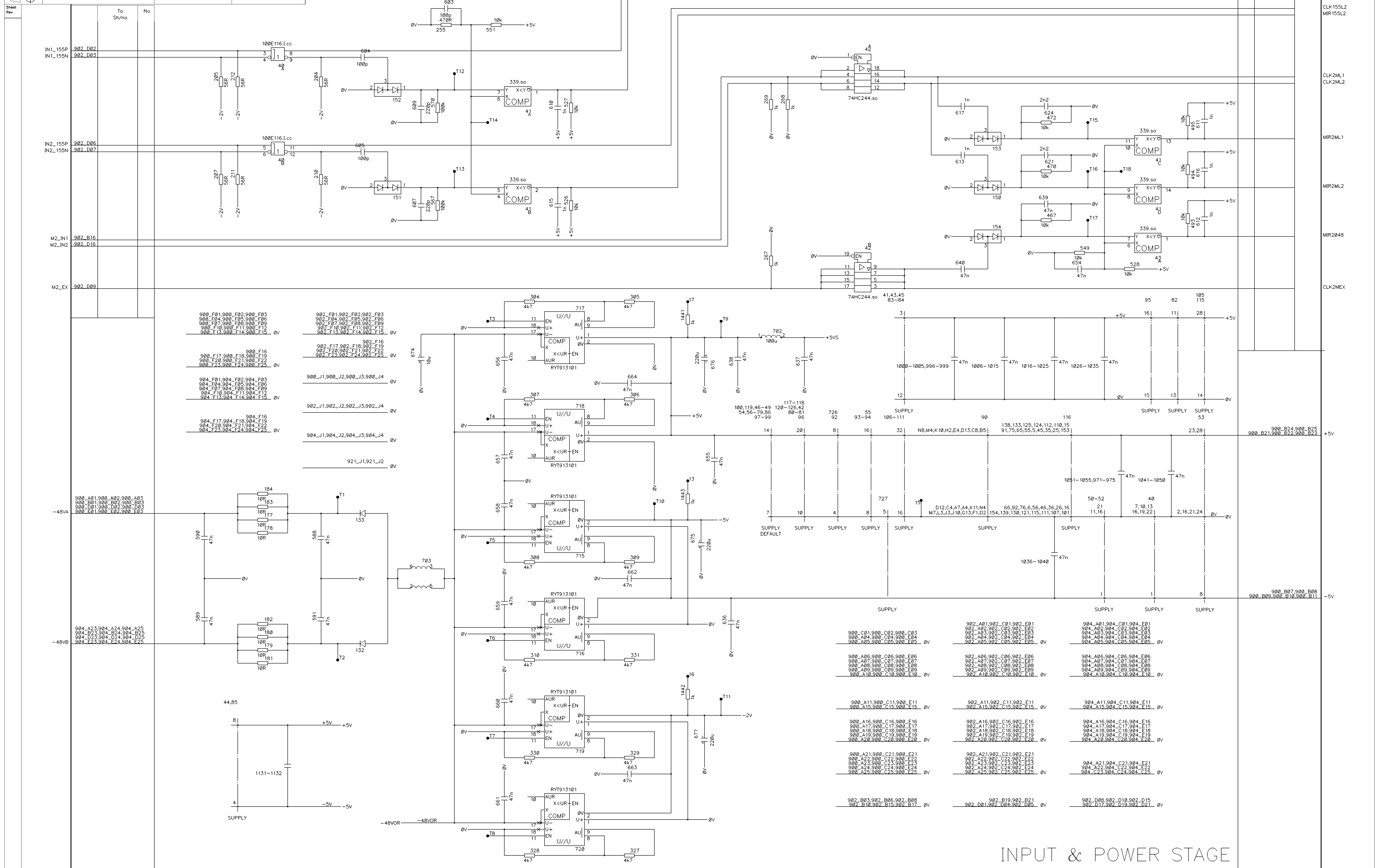

No	To Sh/no
	CLK155L1
	MIR155L1
	CLK155L2
	MIR155L2
	CLK2ML1
	CLK2ML2
	MIR2ML1
	MIR2ML2
	MIR2048
	CLK2MEX

INPUT & POWER STAGE

Eseguito - Prepared TH/A C. Mozetic Resp. del documento/Approvato - Doc. respons/Approved TH/A A. Putorti	Resp. del contenuto - Subj. resp. - Doc. respons/Approved -	No. 1911-ROJ21213/1 Ux Data - Date 1993-10-27 PA2 Rev. - File - Title PRINTED BOARD ASSEMBLY ATM CLOCK BOARD Regole di disegno - Drawing rules Sfr. - Ref.
--	--	--

TP FROM 21 TO 50

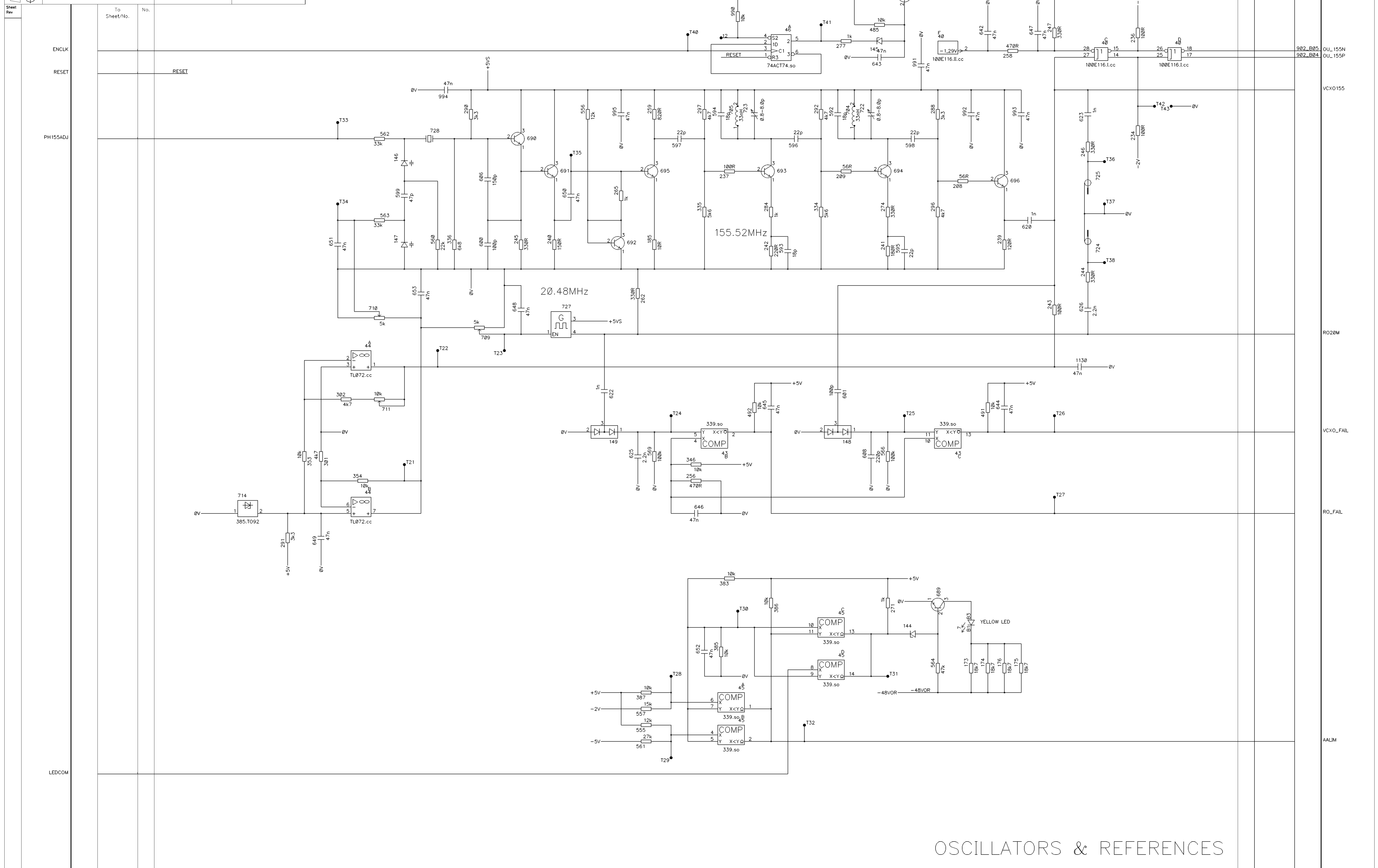

OSCILLATORS & REFERENCES





Eseguito - Prepared	Resp. del contenuto - Subj. resp.	No.	1911-ROJ21213/1 Ux
TH/A C. Mozetic	-	Data - Date	1993-10-27 PA2
Resp. del documento/Approvato - Doc. respons/Approved	TH/A A. Putorti	Rev.	-
Denominazione		Title	
ATM CLOCK BOARD		PRINTED BOARD ASSEMBLY	
Tolleranze - Tolerances		Regole di disegno - Drawing rules	
-		Rif. - Ref.	

TP FROM 121 TO 160

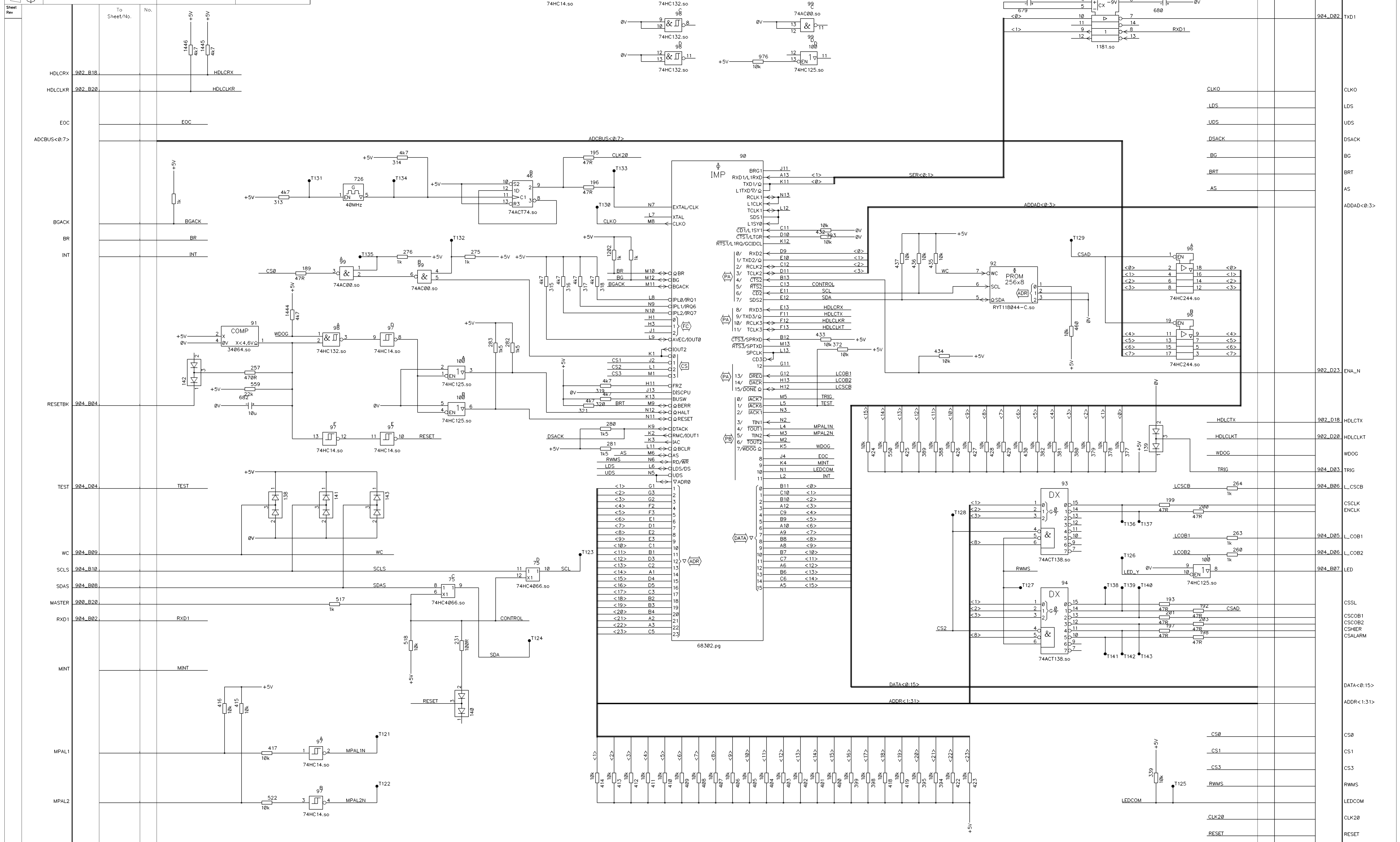



Eseguito - Prepared	Resp. del contenuto - Subj. resp.	No.	1911-ROJ21213/1 Ux
TH/A C. Mozetic	-	Data - Date	1993-10-27 PA2
Resp. del documento/Approvato - Doc. respons/Approved	TH/A A. Putorti	Rev	-
Denominazione		Title	
ATM CLOCK BOARD		PRINTED BOARD ASSEMBLY	
Tolleranze - Tolerances		Regole di disegno - Drawing rules	
		Sfr. - Ref.	

TP FROM 181 TO 190

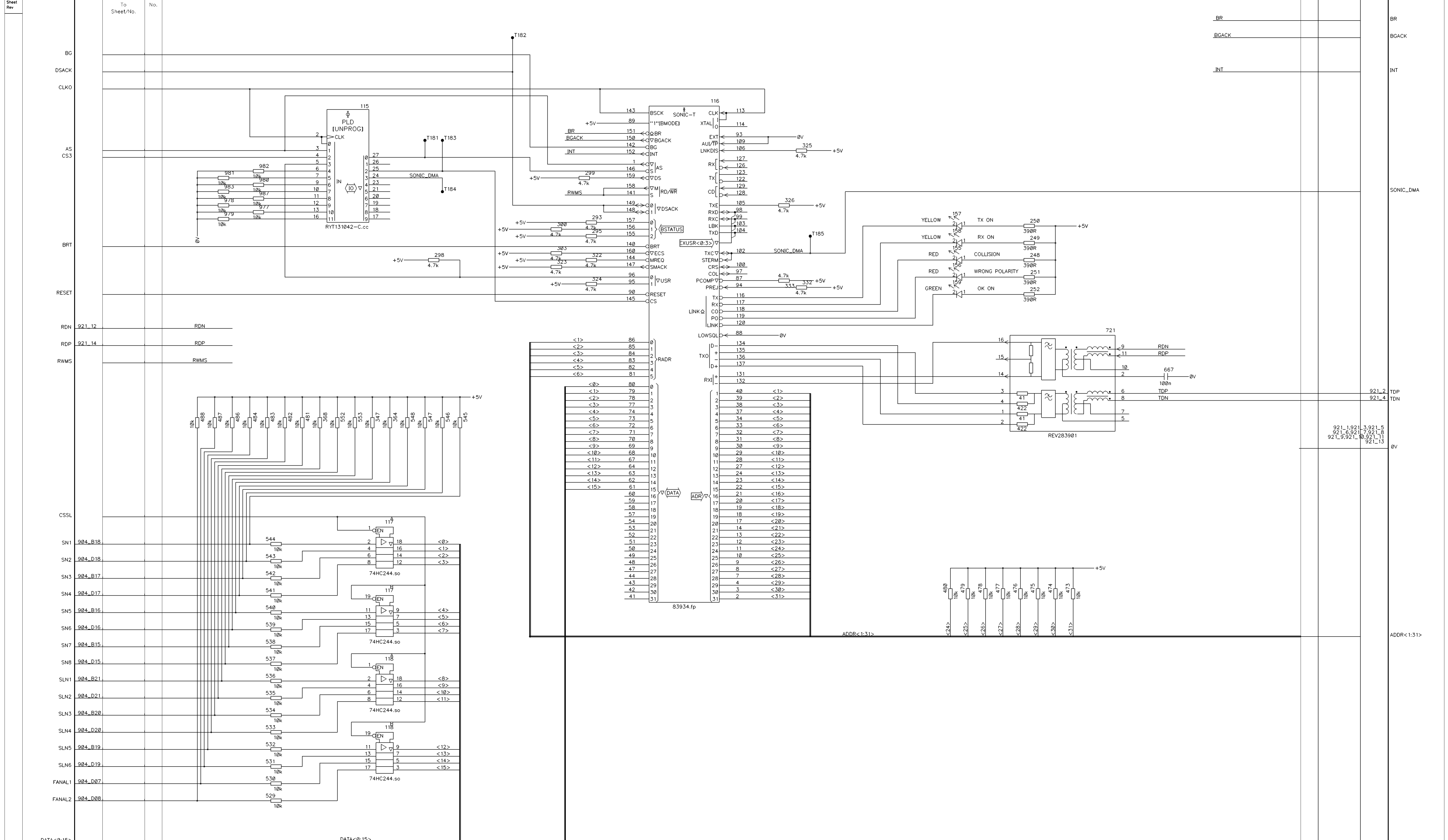

ETHERNET

Eseguito - Prepared	Resp. del contenuto - Subj. resp.	No.
TH/A C. Mozetic	-	1911-ROJ21213/1 Ux
Resp. del documento/Approvato - Doc. respons/Approved	Doc. respons/Approved	Data - Date
TH/A A. Putorti	-	1993-10-27 PA2
Denominazione		Titolo
ATM CLOCK BOARD		PRINTED BOARD ASSEMBLY
Tolleranze - Tolerances		Regole di disegno - Drawing rules
		Rif. - Ref.

Sheet	To	No.
Rev.	Sheet/No.	

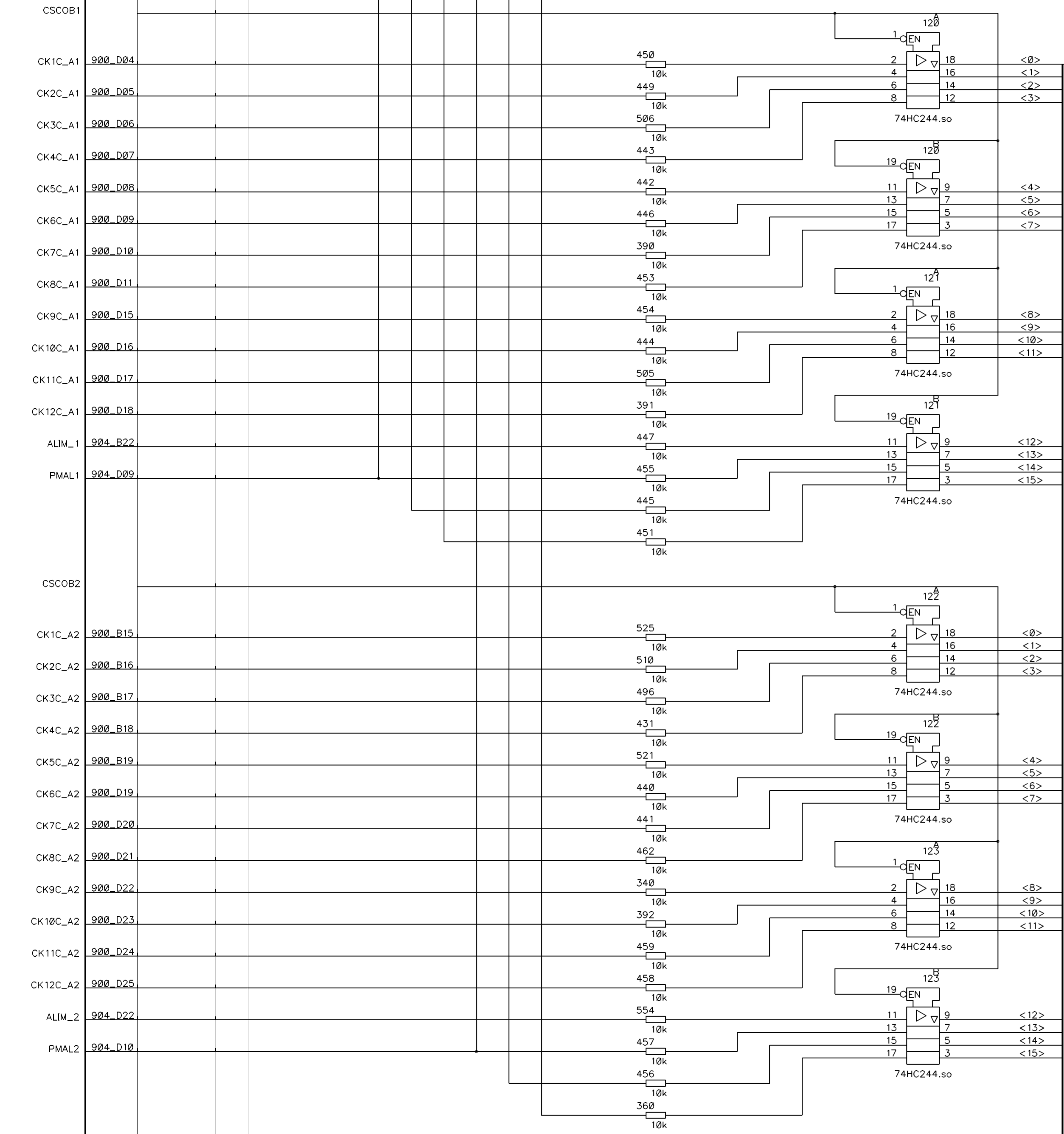
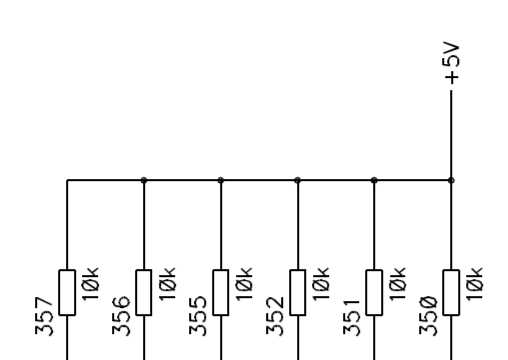

DATA<0:15> DATA<0:15>

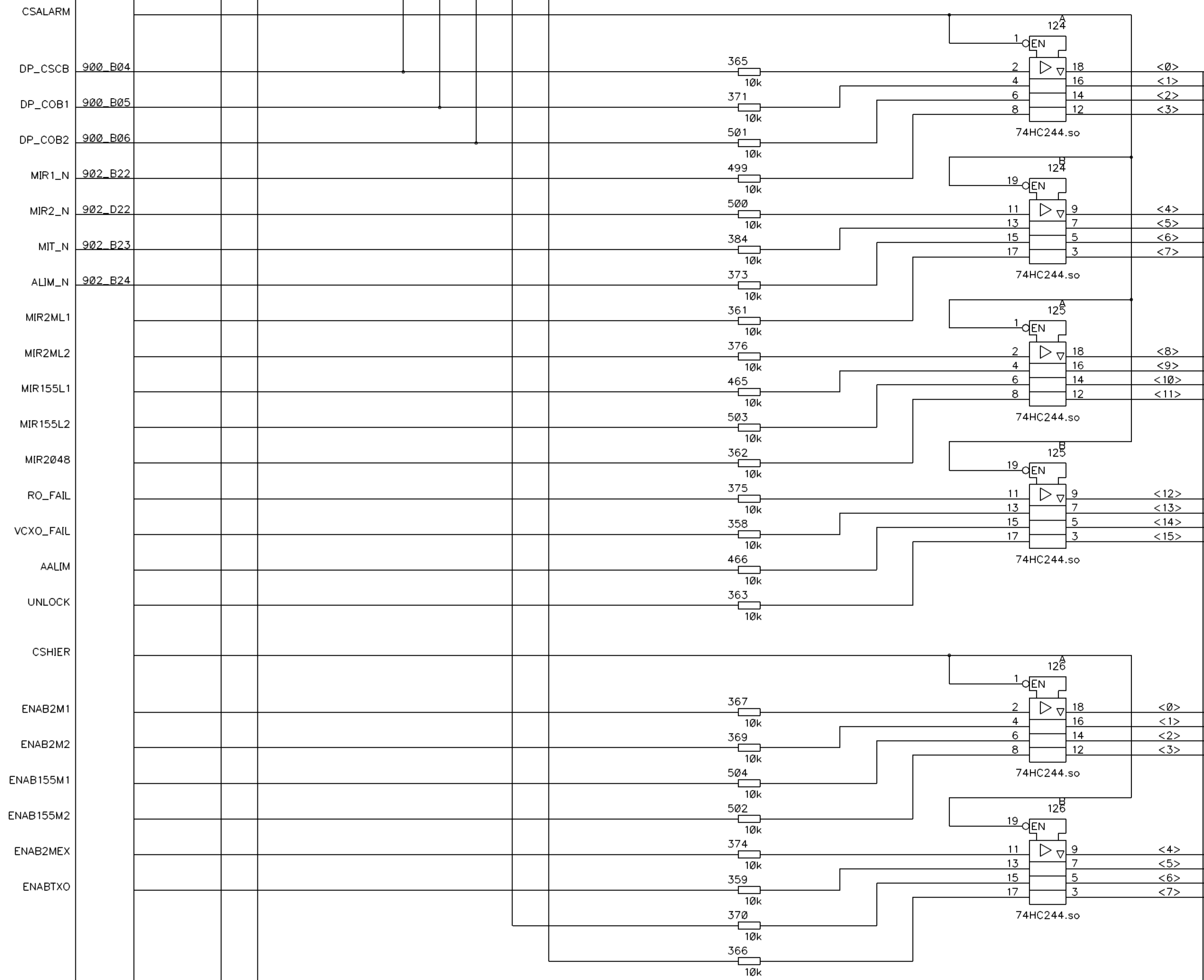
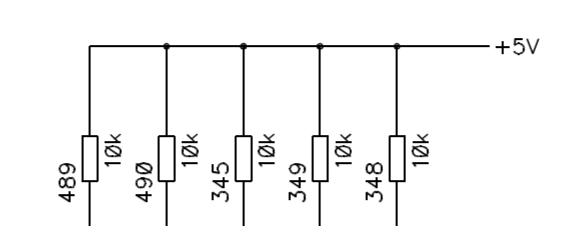

DATA<0:15> DATA<0:15>

DATA BUS EXTENSION

No.	To	No.
	Sheet/No.	